



Bus Parklet Design Manual



Acknowledgements

Alameda-Contra Costa Transit District

Michael Eshleman

Kathryn Vo

Carissa Lee

Community Design + Architecture

Deepak Sohane

Thomas Kronemeyer

Phil Erickson

Ryan Furcini

Abby Granberry

Strategic Economics

Sujata Srivastava

Carline Au

Special Thanks

City of Albany: Chelle Putzer

City of Berkeley: Eleanor Hollander and Diana Riggs

City of Oakland: Laura Kaminski and Sarah Fine

City of Portland: Sarah Figliozi

City of San Francisco: Ilaria Salvadori

King County Metro: Dale Cummings and Owen Kehoe

San Francisco Municipal Transportation Authority: Dustin White

Translink: Stephen Newhouse

TriMet: Ben Baldwin

Table of Contents

1. Manual Overview	5	4. Bus Parklet Design Elements	33
1.1 Project Background.....	6	4.1 Bus Parklet Platform and Platform-Sidewalk Interface.....	34
1.2 Bus Parklet Goals.....	7	4.2 Bus Stop Zone Amenities	36
1.3 Approach to Bus Parklet Guidance.....	8	4.3 Parklet Zone Amenities	40
1.4 Parklet Design and Application Process.....	9	4.4 Other Bus Parklet Design Elements	43
1.5 Manual Outline.....	10		
2. Bus Parklet Siting Considerations.....	11	5. Bus Parklet Site Design Prototypes	47
		5.1 Parallel On-Street Parking	48
		5.2 Angled or Perpendicular On-Street Parking	54
3. Bus Parklet Design Recommendations.....	17	6. Bus Parklet Maintenance	65
3.1 Bus Parklet Sizing	18		
3.2 Bus Parklet Setbacks	20		
3.3 Bus Parklet Functional Zones.....	22		
3.4 Summary of ADA Considerations	31	7. References/Endnotes	67

Appendices

1. Funding Strategy	71
2. Parking Loss Calculator	77
3. Albany Bus Parklet Drawings	80

1. Manual Overview

The purpose of this manual is to outline the possibilities associated with the bus parklet concept and provide guidance to prospective bus parklet sponsors, AC Transit staff, designers, and staff from local jurisdictions in AC Transit's service area related to the design and implementation of bus parklets.

What is a Bus Parklet?

A Bus Parklet combines the popular concept of parklets – relatively low-cost structures that function as an extension of the sidewalk into the adjacent parking lane and create a flexible public space to meet the needs of the local community – with a temporary platform for an enhanced transit boarding experience.

1.1 Project Background

1

Transit agencies, including AC Transit, are well-aware of the benefits that flow from in-lane stopping of buses at bus stops that are configured as permanent bus bulbs as opposed to standard curbside or pull-out type bus stops. These benefits include:

2

- Expansion of sidewalk space for new amenities, such as seating, bike racks, wayfinding signage, and other potential streetscape elements;
- Reduction of parking impacts of transit stops due to in-lane stopping of the bus;
- Reduced dwell time for buses at bus stops as boarding and alighting takes place;
- Reduction of crossing distances for pedestrians at intersections; and,
- Improved pedestrian accessibility to ground-floor retail due to wider sidewalk space along bus stops.

3

4

5

On the other hand, permanent bus bulbs can be expensive to construct, particularly if their construction requires modifications to stormwater facilities or other utility related work. Permanent bus bulbs may also trigger time-consuming and often expensive environmental review, traffic analysis, and possibly litigation. These factors and potential concerns from the public or elected officials over permanent changes in the public right-of-way can significantly delay the implementation of bus bulbs or prevent it all together.

6

7

In response, AC Transit staff are exploring an alternative approach to delivering the benefits of bus bulbs while avoiding some of the pitfalls involved in their implementation. This alternative approach combines the concept of parklets – relatively low-cost structures that provide the benefits of a sidewalk curb extension and create a flexible public space to

meet the needs of the local community – with a temporary platform for an enhanced transit boarding experience. The resulting bus parklet, or buslet, is a welcomed improvement on suitable commercial corridors where demand for transit service improvements often competes for space with on-street parking along the corridor. This approach is encouraged by the mainstream recognition the parklet concept has been gaining in many cities around the country, including several cities in AC Transit's service area (e.g. pilot programs in Oakland and Berkeley). In particular, San Francisco's long-term parklet program has resulted in dozens of small-scale public spaces, usually outside cafes or restaurants, and provides a rich resource of experience, as documented in their comprehensive Parklet Manual.

AC Transit has advanced the bus parklet approach in lieu of permanent bus bulbs by:

1. Preparing this design manual with recommendations and guidance for the implementation of bus parklets, and,
2. Partnering with the City of Albany to construct the first shared transit stop/parklet on Solano Avenue.

By further exploring and documenting the bus parklet concept, AC Transit is looking for opportunities to:

- Take a leading role in tactical transit projects,
- Provide input on future parklet policies of cities in AC Transit's service area and the potential inclusion of bus parklets as an available option,
- Engage private partners to ensure a successful program, and
- Create better environments for pedestrians and bicyclists using transit.

1.2 Bus Parklet Goals

In pursuing the concept of bus parklets, AC Transit's goals include the following:

Provide a Safe and Comfortable Transit Passenger Environment for AC Transit Patrons

Bus parklets have potential for creating a pleasant environment for transit passengers while providing additional benefits, specifically:

- Bus parklets are a cost-effective solution of providing temporary bus bulbs at a bus stop. Bus operations benefit from in-lane stopping and the transit passengers benefit from having a dedicated space for boarding and alighting activities,
- Bus parklets eliminate the need for a bus operator to pull-in and pull-out at a bus stop, thereby greatly improving the overall bus transit travel times and reliability along a corridor
- Bus parklets create a dedicated space to accommodate bus stop amenities, thereby clearing the space along the sidewalk for pedestrian movement and amenities, and
- Bus parklets simultaneously encourage walking, biking and the use of transit.

Support Local Business

Bus parklets can support local business by providing seating and other potential amenities to business patrons. The concept of a bus parklet alleviates impacts to adjacent business as it relocates bus stop functions from the sidewalk to a platform in the parking lane and therefore increases the available sidewalk space. This increase in space promotes a more comfortable walking environment for pedestrians, enhances access to transit, and supports business related activities, such as café seating. Because of these benefits, the owners of adjacent businesses may be more receptive to a bus parklet approach. In addition, Bus parklets can activate the street environment and draw attention to businesses that surround the one in front of which it is located.

Create Public Open Space

Bus parklets are a cost-effective way to add small-scale open spaces to the public realm, fostering social engagement, and building community. Through the use of plants, artistic treatments of design elements, bicycle racks, and seating, bus parklets not only enhance the passenger environment but also the overall streetscape.

1.3 Approach to Bus Parklet Guidance

1

It is important to preface the recommendations in this manual with the acknowledgement that bus parklets are a new design concept that – with the exception of the recently completed pilot bus parklet on Solano Avenue in Albany – do not have a precedent. The approach taken by this manual for providing guidance for the future implementation of more bus parklets is based on deriving its recommendations from existing best practices for the design of bus bulbs and “conventional” parklets. It is important, however, to keep in mind that the initial recommendations put forward here will require further refinement once feedback from designers, operators, and users of bus parklets becomes available in the future. Until this input from local jurisdictions is incorporated into this manual at some point in the future, the recommendations provided herein should be seen as:

2

3

4

5

6

7

- Supplemental to applicable siting, design, and construction requirements contained in already established by local parklet programs;
- A resource that provides guidance that is specific to design characteristics of bus parklets and would not be contained in guidelines and design parameters that cover conventional parklets; and,
- A basis for further coordination of efforts between all involved parties and discussion of details related to the implementation of bus parklets.

The recommendations in this manual focus on the siting and design of bus parklets and therefore, are supplemental to AC Transit’s existing standards and guidelines, such as the *AC Transit Bus Stop Policy*, *Designing with Transit*, and *Multimodal Corridor Guidelines*. For this reason, the manual does not include bus operational considerations related to the spacing of bus stops or whether a bus stop should be located in a near- or far-side location. It is assumed that the process of implementing bus parklets includes the involvement of AC Transit operational staff in weighing whether a sponsors’ preferred location for a bus parklet is compatible with the agency’s operations needs.

The manual’s recommendations are a direct result of the review of best practices for the design of permanent bus bulbs and parklets. In particular, the guidance provided in San Francisco’s *Parklet Manual* (Version 2.0, Spring 2015) proved instrumental for the preparation of initial recommendations for the siting and design of bus parklets. No other current parklet program provides information as detailed as San Francisco’s. The recommendations in this manual are also informed by input on bus bulbs and parklets received during the interviews with transit agency and jurisdictional parklet program staff that were conducted in advance of the preparation of this manual in the Spring of 2018. Additional resources used for the development of recommendations include the design plans for the recently completed first bus parklet on Solano Avenue (in the City of Albany), NACTO’s *Transit Street Design Guide*, and AC Transit’s publications *Designing with Transit* and *Multimodal Corridor Guidelines*.

1.4 Bus Parklet Design and Application Process

As AC Transit does not own the public rights-of-way on which its buses operate, the approval of proposed bus parklets will occur following whichever parklet-related approval process has been established by the respective local jurisdiction in which a proposed bus parklet is located. In cities that already have a (pilot) parklet program, the approval process for a bus parklet may just follow the already established process for the approval of parklets, with possible adjustments to account for aspects unique to bus parklets. This may include the consideration of recommendations in this manual and the additional involvement by and coordination with AC Transit, and possibly jurisdiction public works staff. In cities, that do not have a parklet program, it is recommended that the sponsor work with AC Transit and the respective local jurisdiction during the early concept stage of the design process to identify all involved application, design, and construction approval requirements and coordination steps. The bus parklet sponsor will be responsible for taking the lead in carrying out all stages of the parklet approval process. AC Transit will provide its support to the sponsor on a case-by-case basis.

It is anticipated that the installation of a bus parklet will adhere to the following process:

Initiation of Bus Parklet Approval

The bus parklet sponsor will notify local jurisdiction staff and AC Transit of the intent to apply for the construction of a bus parklet. The notification of and obtaining consent from adjacent businesses and other stakeholders or members of the local community will follow the existing parklet application and approval process of the respective local jurisdiction. The sponsor will be responsible for submitting any documentation that may be required by the local jurisdiction for the approval of

the identified bus parklet location. AC Transit staff will also review the proposed location and provide its comments to the applicant and local jurisdiction. In cities that do not have a parklet program, the sponsor will work with the local jurisdiction to establish the application and approval process for the bus parklet. AC Transit may support the sponsor in this effort on a case-by-case basis.

Develop Draft and Final Bus Parklet Design Plans

Upon the approval of the location from the local jurisdiction and AC Transit, the sponsor will develop the design for the bus parklet from an initial concept proposal to plans for construction. The applicant will work with the local jurisdiction and AC Transit all through the design process to identify and address site-specific constraints. The sponsor is encouraged to engage an architect, engineer, landscape architect or other licensed professional in the design process. Depending on the specifics of the local approval process, the sponsor will be responsible for submitting any required draft and final design and construction drawings and pay any applicable fees for a permit to install the proposed bus parklet. AC Transit may support the sponsor's efforts on a case-by-case basis.

NOTE: Some jurisdictions may require that the final plans be stamped by an architect, engineer, or other design professional.

Bus Parklet Installation

Upon the issuance of a building permit by the local jurisdiction, the sponsor will be responsible for the installation of the bus parklet within the timeframe and other parameters associated with the installation process, such as traffic control, as defined by the local jurisdiction.

1.5 Manual Outline

The Bus Parklet manual is organized into the following chapters:

Chapter 2: Bus Parklet Siting Considerations

Provides an overview of characteristics for the selection of streets and sites appropriate for the implementation of bus parklets.

Chapter 3: Bus Parklet Design Recommendations

Provides guidance on bus parklet sizing and positioning and design considerations for a bus parklet's functional zones and sub-areas as well as a summary of critical access requirements for the disabled.

Chapter 4: Bus Parklet Design Elements

Elaborates on key bus parklet design elements and their desired characteristics, including design considerations for the platform and its interface with existing sidewalks.

Chapter 5: Bus Parklet Site Design Prototypes

Provides critical dimensions and basic layouts for the most common combinations of stop locations and on-street parking and curb configurations along urban streets that are likely candidates for the implementation of bus parklets.

Chapter 6: Bus Parklet Maintenance

Provides a brief overview of maintenance responsibilities associated with bus parklets.

A funding strategy for the implementation of bus parklets is included as *Appendix 1*.



2. Bus Parklet Siting Considerations



Not all streets and sites are suitable for the implementation of a bus parklet. This chapter discusses the most relevant traffic, roadway, and site characteristics that need to be assessed to determine whether or not the implementation of a bus parklet is appropriate. The characteristics addressed below include:

- Posted Speed Limit
- Number of Travel Lanes
- On-Street Parking
- Bulb-outs/Curb Extension
- Stop Location
- Sidewalk Width
- Longitudinal and Cross Slope
- Driveways
- Curb Zones
- Existing Utilities and Vertical Curbside Elements
- Near-term or Long-term Street Improvement Projects
- Streets with Bicycle Facilities

Posted Speed Limit

Bus parklets should only be considered on streets with posted speed limits of 25 mph or less¹. Potential locations with speed limits over 25 mph may be considered on a case-by-case basis based on a detailed review and assessment of roadway geometrics, sight distances, collision data, and speed surveys by a professional traffic engineer.

Number of Travel Lanes

Bus parklets can be considered for streets that have one or two travel lanes in each direction as long as the posted speed limit does not exceed 25 mph (*see above*).



Posted Speed Limit not to exceed 25 mph

On-Street Parking

Bus parklets are only compatible with roadways that include on-street parking into which the bus parklet can be integrated. Bus parklets are generally compatible with on-street parking that is configured as parallel, angled, or perpendicular. The space for on-street parallel parking needs to be at least seven (7) feet wide in order to accommodate a bus parklet.

Bus parklets should typically be installed at existing bus stop locations where a length of red curb is already in place and therefore does not require the removal of on-street parking. In locations where this length of red curb is consistent with AC Transit's dimensions of a standard near- or far-side stop², the recommended dimensions of a bus parklet and its setbacks (*see Chapter 5*) will not require the elimination of any parking spaces.

In locations with an inadequate length of red curb to accommodate a bus parklet sized at its minimum recommended dimensions (*see Chapter 5*) or when a sponsor pursues a larger than minimum bus parklet, this may impact existing on-street parking. The potential resulting loss of parking spaces needs to be assessed on a case-by-case basis. In such cases, AC Transit and the bus parklet sponsor should work with the local jurisdiction and project site stakeholders to determine the appropriate mitigation, if any.

If a bus parklet is installed in locations without an existing bus stop or as part of a bus stop relocation process, a minimum of three parking spaces will likely be impacted. *See Appendix 2* for a discussion of the estimated loss of on-street parking spaces for near-side and far-side stop locations.

1

2

3

4

5

6

7

In cases where on-street parking is metered, and more on-street parking spaces are displaced by a bus parklet than can be replaced nearby, consideration needs to be given to the potential loss of parking fee revenue. Lost parking revenue could be waived by the local jurisdiction or may need to be borne by the bus parklet sponsor and/or another party.

Bulb-Outs/Curb Extensions

Bus parklets are generally compatible with corner or mid-block bulb-outs (sometimes also referred to as curb extensions or sidewalk widening). The functionality of a bus parklet can potentially be increased by an adjacent bulb-out as it provides additional space for amenities installed by a city or other party, such as trash receptacles, bicycle parking, seating, or landscaping.

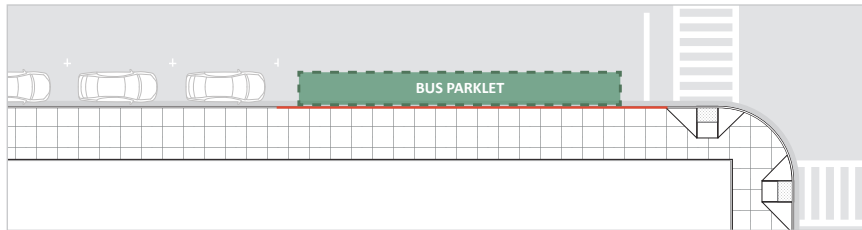

Parallel On-Street Parking

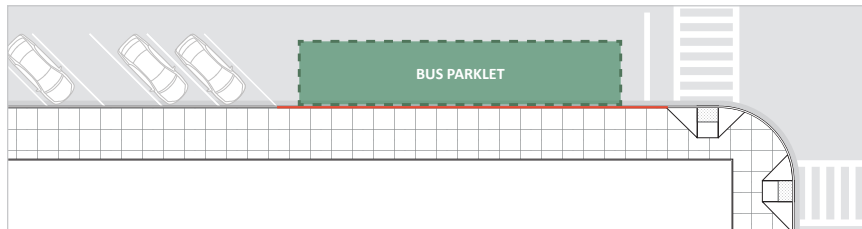

Angled On-Street Parking

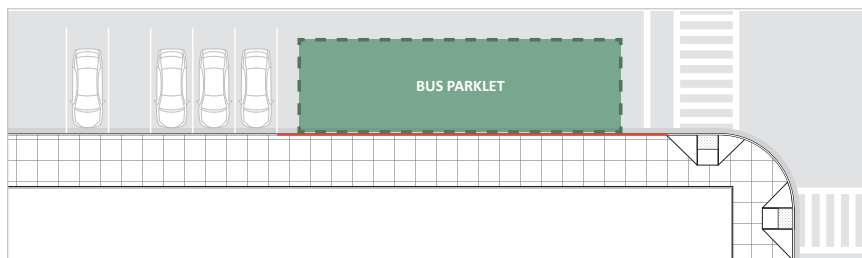

Perpendicular On-Street Parking

- 1
- 2
- 3
- 4
- 5
- 6
- 7

Bus Stop Location

Bus parklets can be located to function as stops in near-side, far-side, or mid-block locations. This provides some flexibility in meeting both, AC Transit’s bus operational needs and the sponsor’s desire to locate an outdoor space in proximity of sponsor’s business or other establishment. If a sponsor’s desired bus parklet location and AC Transit’s desired bus stop location do not coincide, AC Transit will decide on a case-by-case basis, if the implementation of a bus parklet in the sponsor’s proposed location should be supported.

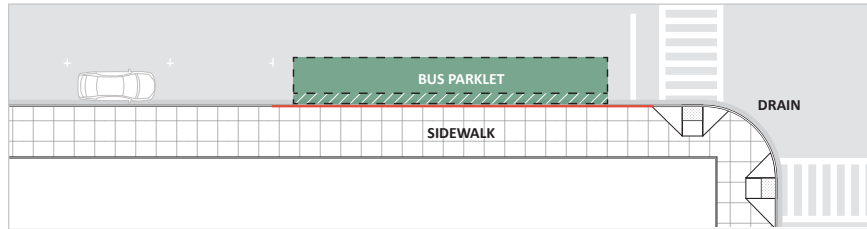

Near-side Bus Stop Location

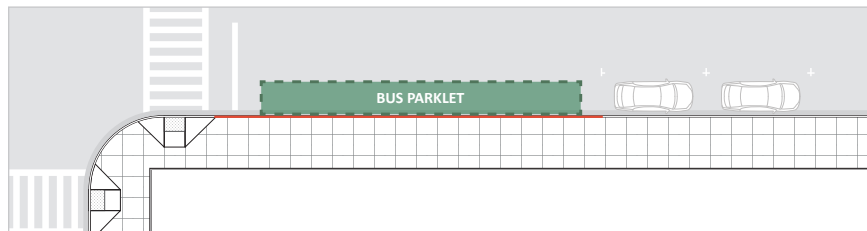

Far-side Bus Stop Location

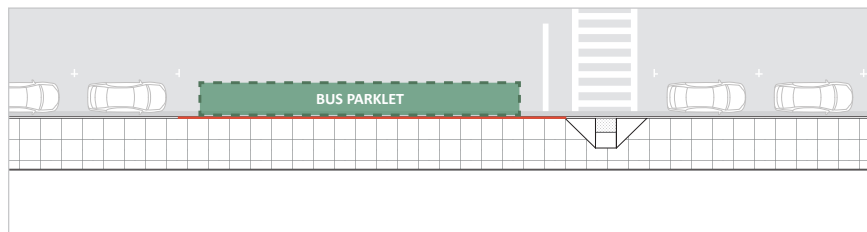

Mid-block Bus Stop Location

Sidewalk Width

On streets with seven- to eight-foot wide parallel on-street parking, the ADA Landing Area of a bus parklet will overlap onto the sidewalk by one or two feet (see Chapter 5: Prototypical Bus Parklet Layouts and Dimension for Parallel On-Street Parking). Bus parklets should only be considered where the parklet-adjacent sidewalk has sufficient overall width to provide an eight-foot (minimum) wide clear area for pedestrian travel after the width of the overlapping ADA Landing Area is accounted for. This clear width recommendation should be applied to blocks with mixed-use, commercial, retail, or higher density residential uses. In the unlikely event that a bus parklet is proposed on a block of low-density residential, a minimum six-foot clear area should be maintained on the sidewalk. The same recommended clear areas for pedestrian travel should be observed for sidewalks along bus parklets on streets with angled or perpendicular parking.

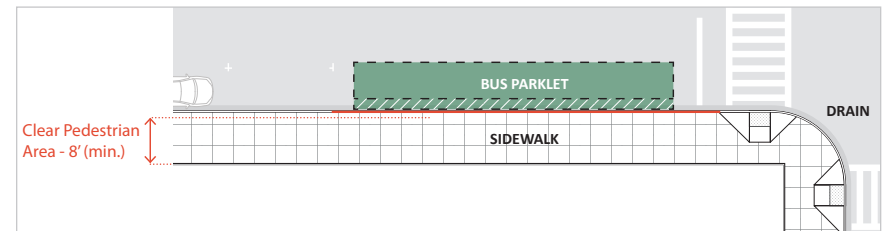

Minimum Sidewalk Width in Commercial Areas

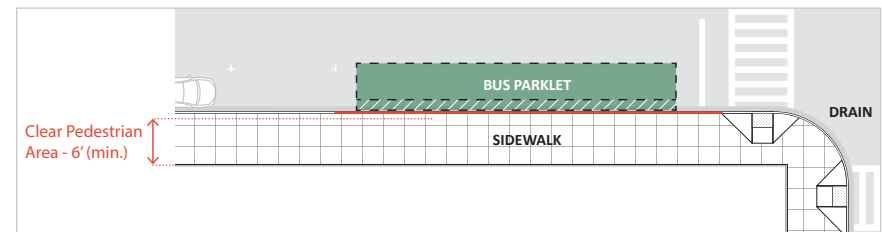

Minimum Sidewalk Width in Low-density Residential Areas

Longitudinal and Cross Slope

Bus parklets should only be considered on streets with a longitudinal grade of five percent or less. Potential locations on streets with a grade greater than five percent may be considered on a case-by-case basis if the bus parklet can be designed to accommodate safe and comfortable access for wheelchair users.

The cross slope of the bus parklet’s platform must not exceed the two percent cross slope allowed by ADA requirements for a compliant path of travel. For this reason, bus parklets should not be installed in locations where the crowning of the roadway surface and other local roadway grades result in a cross slope of the platform surface that exceeds two percent.

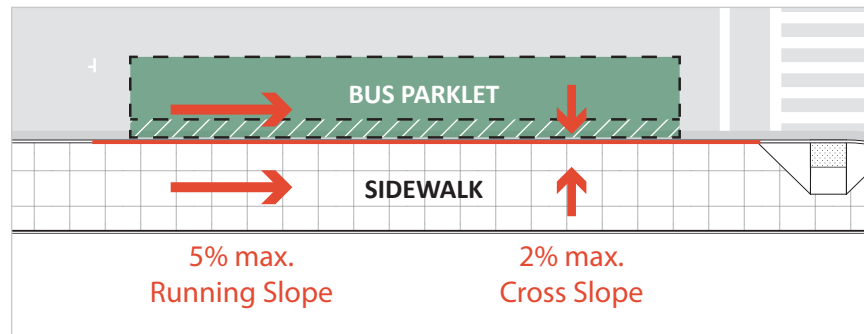

Longitudinal and Cross Slope

Driveways

Bus parklets may be installed in front of an existing driveway if the bus parklet sponsor is the owner of the property served by the driveway or if consent can be obtained from the owner of the property that is served by the driveway. In addition, it should be carefully analyzed whether all required ADA access requirements for both the bus stop and parklet portions of the bus parklet can be achieved if the driveway is left in place. If this is not the case, and where a bus parklet is located at a defunct driveway, the driveway should be leveled as part of the project.

Curb Zones

Bus parklets should be located within the red curb zone of an existing bus stop, whenever feasible. Where the length of the existing red curb zone is insufficient to accommodate the proposed bus parklet (*see Chapter 5*), the red curb zone should be extended at the expense of adjacent on-street parking (*see On-Street Parking above*) or other curb zone designation, including yellow, white, or green zones or motorcycle parking. If space from these zones is needed, the sponsor should work with the local jurisdiction to identify alternative locations for their replacement in the general vicinity of the proposed bus parklet. If a proposed bus parklet locations conflict with a blue zone for disabled parking, the sponsor should work with the local jurisdiction to convert the first parking space adjacent to the bus parklet to a blue zone. If the local jurisdiction is not open to relocating or replacing parking in locations with yellow, white, green or blue zones, such locations should not be considered for a bus parklet. AC Transit may support the sponsor’s coordination efforts around on-street parking and curb zones on a case-by-case basis.

Existing Utilities and Vertical Curbside Elements

Bus parklets should not be considered in locations where the proposed platform would cover utility access panels, manhole covers, or storm drain inlets located in the roadway if these cannot be made accessible through respective provisions in the platform design. In general, bus parklets should be designed so that portions of or the entire bus parklet can be removed to provide access to underground lines if so required by a local jurisdiction or utility company whose utility lines are covered by the bus parklet.

Close attention also needs to be given to the presence of existing utility poles, fire hydrants, parking meters and payment kiosks, light or signage poles, street trees, or any other vertical elements located along the curbside edge of the sidewalk. These should not conflict with bus parklet access points or required clear zones. Some of these objects, such as trash receptacles, signage poles, or other smaller streetscape elements can potentially be relocated to locations along the length of the bus parklet or nearby that are not in conflict with the bus parklet and its access points. Any vertical elements that conflict with the ADA Landing Area of the bus stop portion of the bus parklet or the proposed ADA access point(s) of the parklet portion must either be avoided or relocated (*see Chapter 3.4: Summary of ADA Considerations*). This is particularly important for bus parklets in parallel parking lanes, where the ADA Landing Areas overlap the sidewalk edge by one or two feet.

Near-term or Long-term Street Improvement Projects

Bus parklets should not be installed on streets that are designated for a repaving of the roadway within 24 months as this would require removal of the bus parklet investment before sufficient benefits can be derived from its implementation. On streets slated for significant redesign and reconstruction, the construction of permanent bus bulbs should be considered rather than the implementation of bus parklets.

Streets with Bicycle Facilities

A bus parklet may be considered on streets with an existing or proposed Class III bicycle facility, such as a bike route, bicycle boulevard, or street with sharrows. The bus parklet sponsor should coordinate with the local jurisdiction to verify the feasibility of installing a bus parklet on such streets. AC Transit does not anticipate pursuing the bus parklet concept on streets that have an existing or a proposed Class II (bicycle lanes, or buffered bicycle lane) or Class IV (separated bikeway) bicycle facility.

1

2

3

4

5

6

7

3. Bus Parklet Design Recommendations



After a suitable location for a bus parklet has been identified, the next step in the process is to determine its size, spatial relationship to adjacent crosswalks and parking spaces, and the spatial organization of its various design elements within functional zones and sub-areas that define the layout of a bus parklet. This chapter covers these topics in the following sections:

- Bus Parklet Sizing
- Bus Parklet Setbacks
- Bus Parklet Functional Zones

The chapter ends with a discussion on key considerations for the design of bus parklets to meet accessibility requirements for the disabled.

3.1 Bus Parklet Sizing

1

Bus parklets are sized based on the width of the existing parking lane and configuration of the on-street parking spaces (parallel, angled, or perpendicular). The width of a bus parklet equals the width of an existing parallel, angled, or perpendicular parking lane minus one-foot setback from the adjacent travel lane (see *Section 3.2: Bus Parklet Setbacks*). The length of a bus parklet depends on a number of variables, such as:

2

- The sponsor's desired program for the Parklet Zone;
- AC Transit's need for a larger-than-minimum Bus Stop Zone based on peak boarding/alighting activity;
- The feasibility of removing parking beyond the existing length of red curb at the bus stop that accommodates the bus parklet;
- The presence of vertical objects along the curb edge that cannot be (cost-effectively) relocated;
- The available construction budget; and
- Other local conditions, such as roadway and sidewalk grades, inlets or utility access points that may limit the length of the parklet along the curb.

3

4

5

6

7

Sizes and dimensions of bus parklets reflected in the prototypical layouts in Chapter 5 of this manual were developed based on the following considerations:

- Use minimum dimensions for the Bus Stop Zone (see Bus Parklet Functional Zones) that result in a design that is consistent with core bus stop design requirements already established by AC Transit, functionally and operationally sound, and cost effective in the context of financing strategies available for bus parklets.

The Bus Parklet Prototypes in Chapter 5 achieve this by providing the required ADA Landing Area and bus stop flag (sign).

- Dimension space for the Parklet Zone (see Chapter 3.3) such that its programmable space promotes the interest of potential bus parklet sponsors to take on the financial and maintenance responsibilities associated with a bus parklet.

The Bus Parklet Prototypes in Chapter 5 achieve this by sizing the minimum Parklet Zone to be comparable in length (30 feet) to a regular parklet (typically around 32 feet³) that results from converting two parking stalls after accounting for the required setbacks (four feet from adjacent parking at either end).

- Fit the overall length of a bus parklet within the standard length of red curb for near-side and far-side bus stops to avoid impacts on existing on-street parking.

The Bus Parklet Prototypes described in Chapter 5 achieve this by keeping the combined total length of Bus Stop Zone and Parklet Zone to be equal to or shorter than the standard length of near- and far-side bus stops⁴ as described in AC Transit's *Designing with Transit*.

The size of Bus Stop and Parklet Zones may be increased beyond the recommended dimensions if additional curb space and additional funding for a bus parklet are available. In particular, the possibility of a larger Parklet Zone may promote a sponsor's desire to finance and maintain a bus parklet.

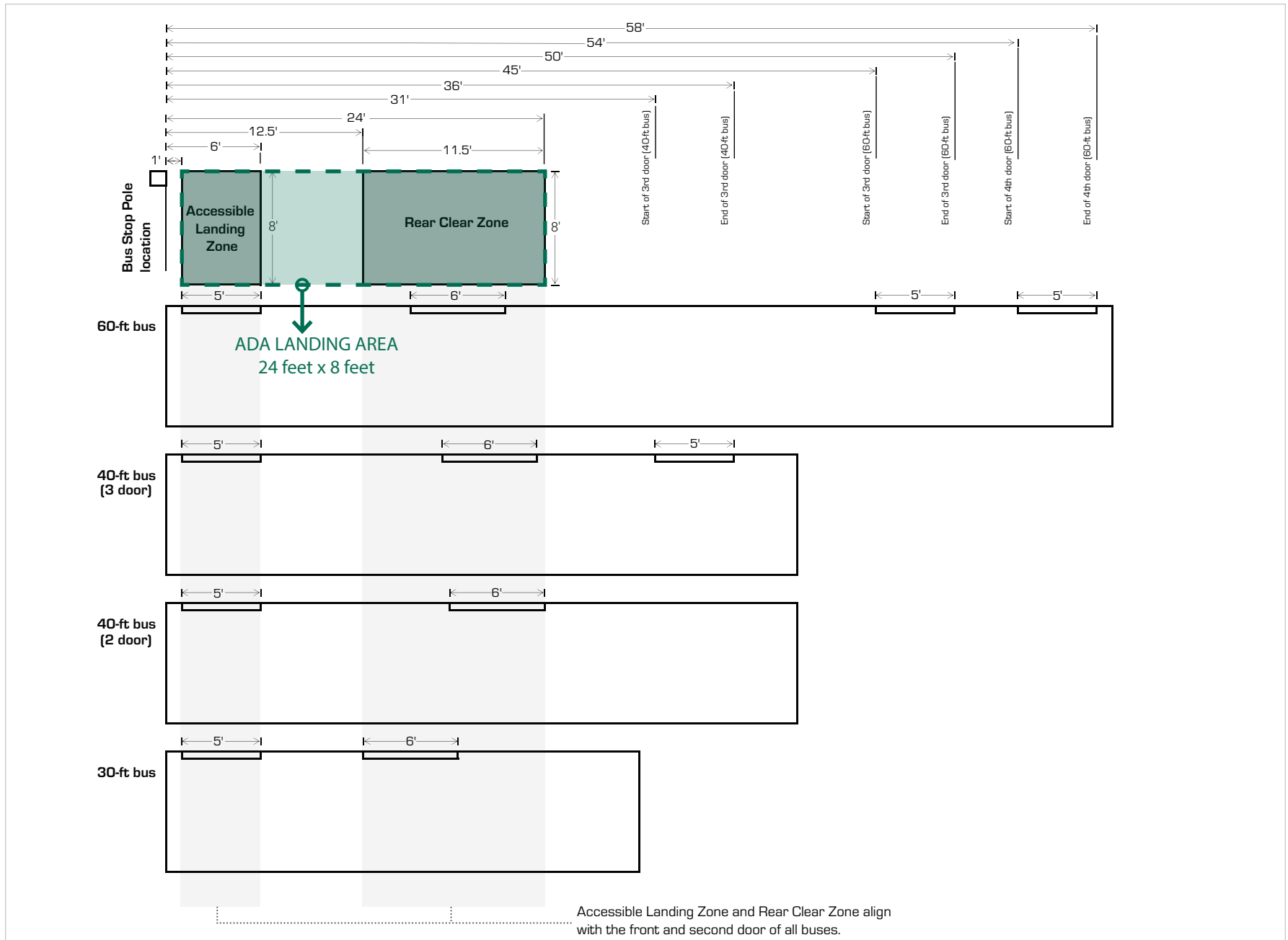

ADA Landing Area for Bus Parklets is derived from ADA Landing Area Dimensions associated with different buses in AC Transit's fleet

3.2 Bus Parklet Setbacks

The following section provides recommendations for setbacks between bus parklets and stopped buses relative to other street design elements, specifically: adjacent crosswalks, travel lanes, and remaining parking spaces. The setbacks from an adjacent travel lane and adjacent parking spaces are necessary to avoid impacts from moving or maneuvering vehicles. The setback of buses stopped at bus parklets is intended to maintain clear sightlines between drivers and pedestrians approaching crosswalks and to establish a clear space behind the bus for a vehicle. The setback dimensions will vary depending on the bus parklet's location and local conditions.

Setbacks from Crosswalks

The following setbacks should be maintained between buses stopped at parklets and adjacent crosswalks:

Near-side location: Locate the bus parklet so that the front of a bus stopped for boarding/alighting is located a minimum of 10 feet⁵ back from the nearest crosswalk edge. The bus parklet structure itself may extend into this setback by up to four feet.

Far-side location: Locate the bus parklet so that the rear of a bus stopped for boarding/alighting is located a minimum of 10 feet⁶ back from the nearest crosswalk edge. The bus parklet structure itself may extend into this setback up to one-foot clear from the crosswalk edge⁷. When feasible, maintain a setback of 20 feet between the rear of a bus and the nearest crosswalk edge in order to provide space for one car to wait behind the stopped bus without blocking the crosswalk⁸.

Mid-block location: Locate bus parklets at bus stops mid-block locations so that the front or the rear of a bus stopped for boarding/ alighting is located a minimum of 10 feet back from the nearest crosswalk edge. For near-side mid-block bus stops, the bus parklet structure may extend into this setback by up to four feet. For far-side mid-block location, the bus parklet structure may extend into this setback by up to one foot clear from the sidewalk edge.

Setback from Adjacent Parking Spaces

Bus parklets should be set back a minimum of four feet from an adjacent parking space where parallel parking occurs and a minimum of three feet from an adjacent angled or perpendicular parking space⁹.

Setback from Adjacent Travel Lane

The outside edge of a bus parklet's red concrete curb should be set back from the striped or functional edge of the adjacent travel lane by one foot.¹⁰

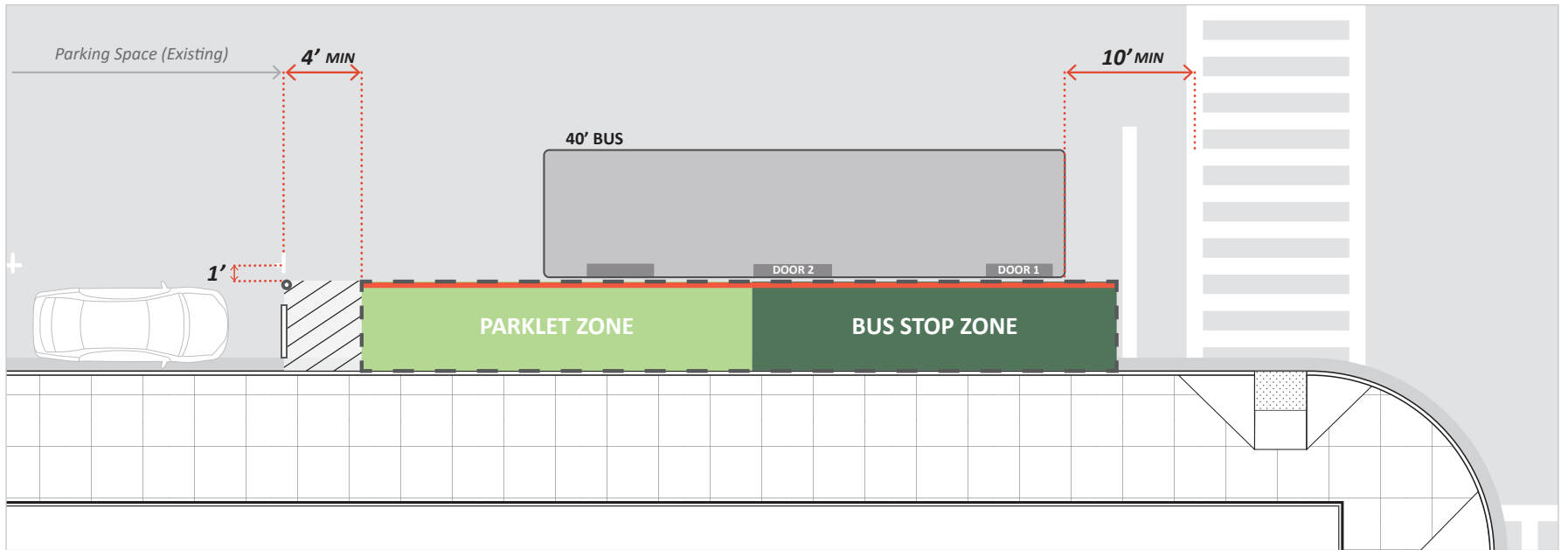

Near-side location - Setbacks from Crosswalks, Adjacent Parking Spaces and Adjacent Travel Lane

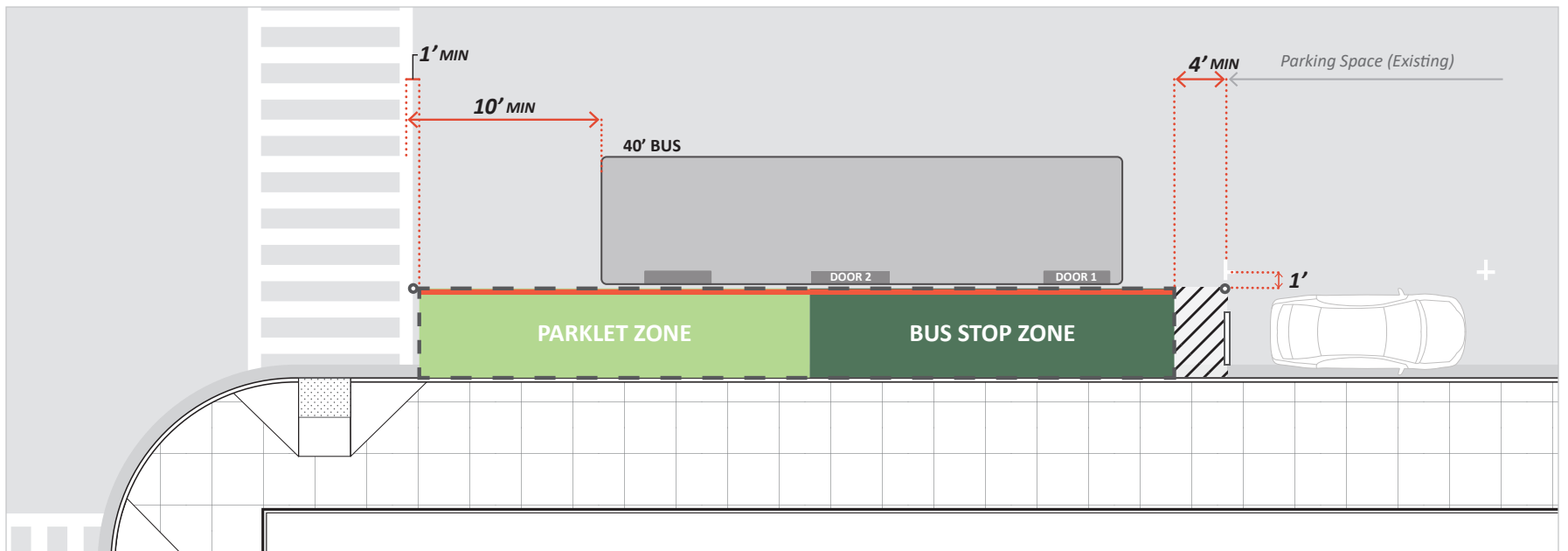

Far-side location - Setbacks from Crosswalks, Adjacent Parking Spaces and Adjacent Travel Lane



3.3 Bus Parklet Functional Zones

Bus parklets are based on the innovative idea of combining the popular concept of a parklet with key elements of a bus stop. While a bus parklet combines parklet and bus stop into a single structure, it is useful to the design process and organization of functional elements and spaces to distinguish two functional zones within the bus parklet – the Bus Stop Zone and the Parklet Zone. This section provides design guidance specific to each of the two zones.

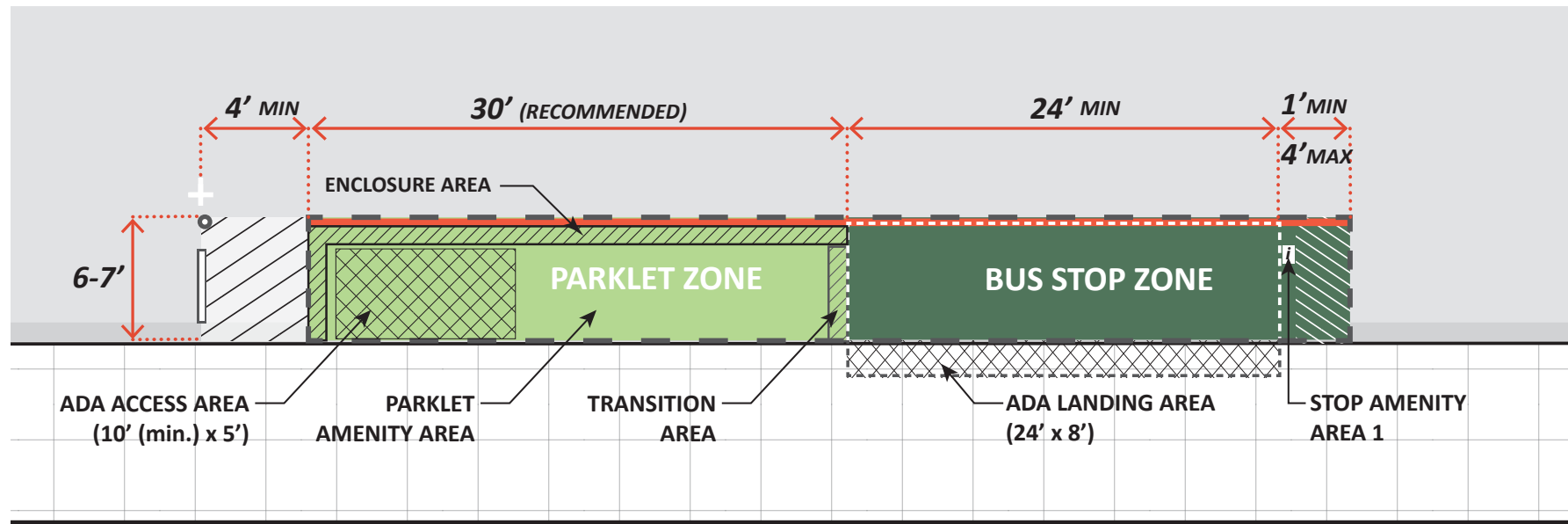

Bus Stop Zone

The Bus Stop Zone of the bus parklet accommodates the primary bus stop related functions, such as boarding and alighting, the flag sign and schedule, and space for the deployment of a bus's ADA ramp, which is located at either the first or second door of the bus, as well as potential seating. The Bus Stop Zone includes the following sub-areas:

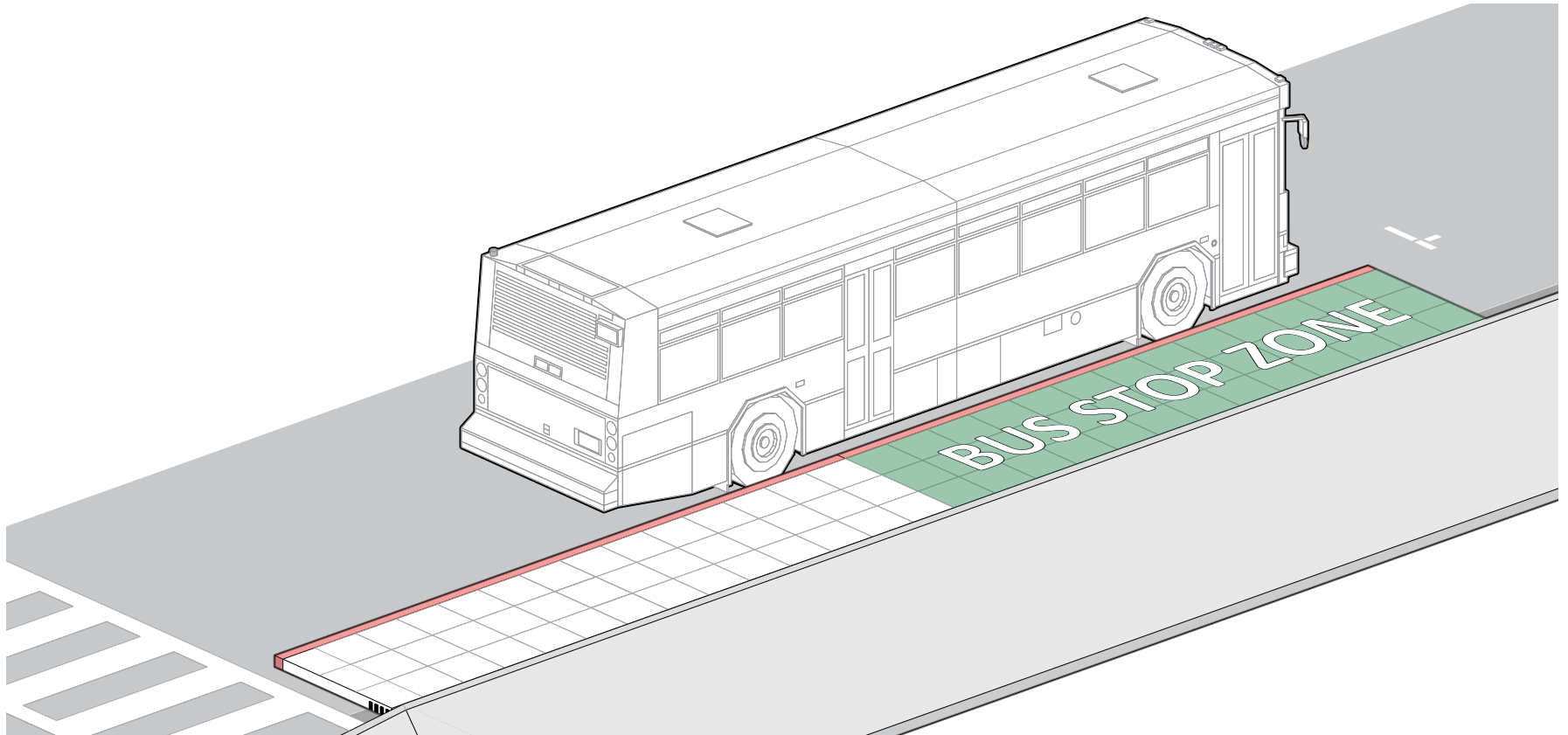

ADA Landing Area

The ADA Landing Area accommodates the deployment of ADA accessible ramps for AC Transit's common bus types. It must be kept clear of any obstructions and not exceed two percent cross slope. The minimum recommended dimension for the ADA Landing Area is 24 feet x 8 feet minimum (10 feet where feasible). The dimension of the ADA Landing Area was developed from the diagram in Figure 3, which provides an overview of door locations on different buses in AC Transit's fleet.

Stop Amenity Area 1

Stop Amenity Area 1 accommodates a required enclosure element that delineates the front end of the bus parklet and the bus stop sign (flag). Its width may range between one foot (minimum) and four feet (maximum). The height above the platform surface of any enclosure element may range from a minimum of 18 inches to a maximum of 42 inches, including the height of any used plants. Where the short end of the bus parklet faces a nearby crosswalk (as is typical for near-side stop locations), the height of any solid enclosure element that is wider than one foot should be limited to 30 inches above the roadway surface in order to avoid obstructing the line of sight.

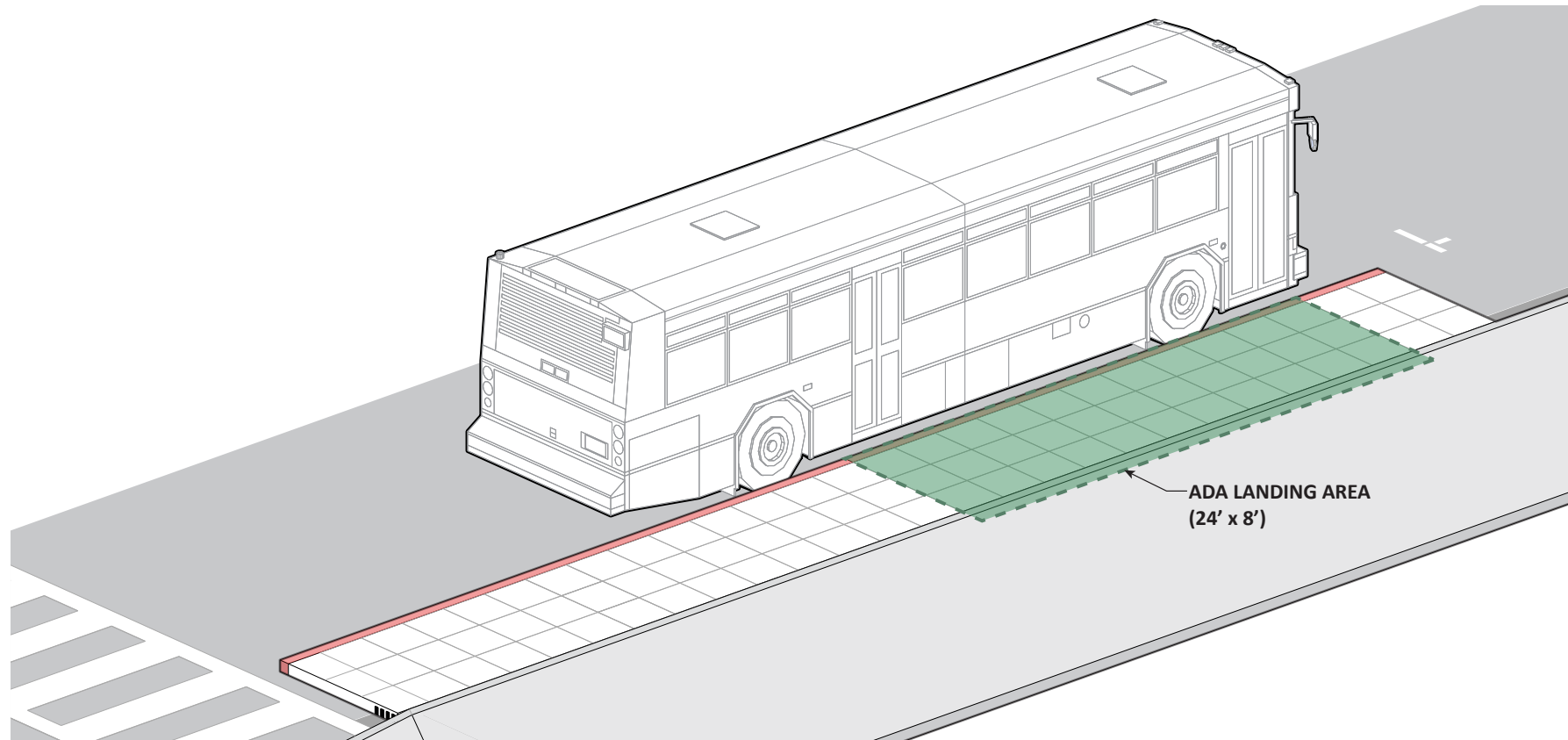

between bus operators and drivers and pedestrians entering the crosswalk¹¹. The 30-inch limit includes the combined height of a planter box and plants, if these are used in the design.

If sized at one foot: At its minimum width, the sole purpose of Stop Amenity Area 1 is to accommodate the bus stop sign (flag) and the required enclosure element, which may be a railing, planter or combination thereof.

If sized at four feet: At its maximum size, Stop Amenity Area 1 can accommodate seating that is integrated into the required vertical enclosure elements described above.

Vertical enclosure elements up to 24 inches in height above the platform surface should maintain an eighteen-inch minimum clearance from the roadside edge of the platform (face of red curb). All vertical elements taller than 24 inches should maintain a two-foot minimum clearance from the roadside edge of the platform.

The bus stop sign (flag) pole should be integrated into the design of the railing, planter or other enclosure element and maintain a two-foot minimum clearance from the roadside edge of the platform (*also see Chapter 4.2 Bus Stop Zone Amenities*).

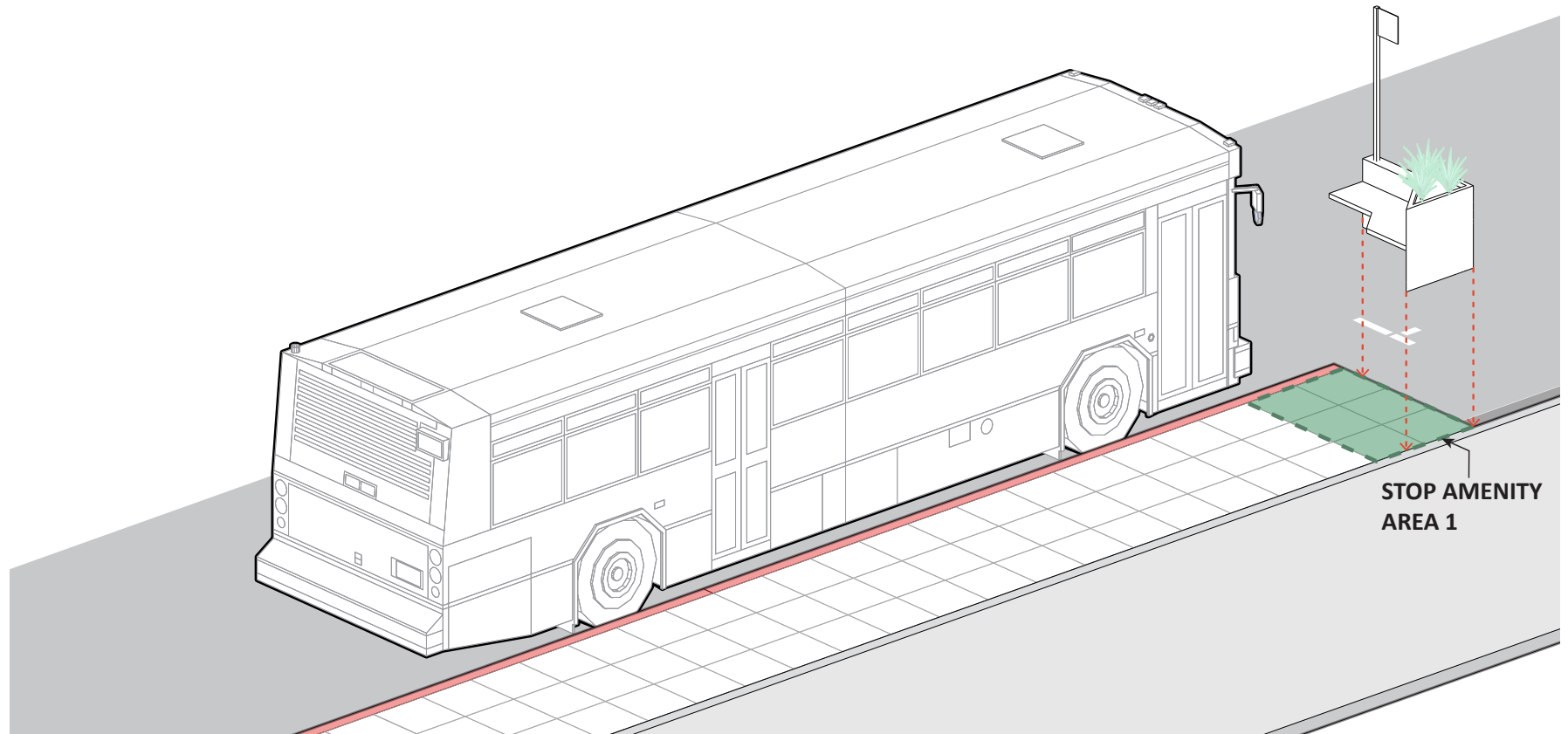

Stop Amenity Area 2 (applicable on bus parklets with adjacent angled or perpendicular parking only)

Stop Amenity Area 2 is comprised of the space between ADA Landing Area and sidewalk on bus parklets with adjacent angled or perpendicular parking. This space may be used for the placement of bus stop amenities such as additional seating or landscape planters as long as a 6-foot wide (minimum) clear path of travel is provided between the sidewalk and applicable bus door locations. The use of design elements placed in Stop Amenity Area 2 may not result in encroachment into the 24' x 8' clear ADA Landing Area.

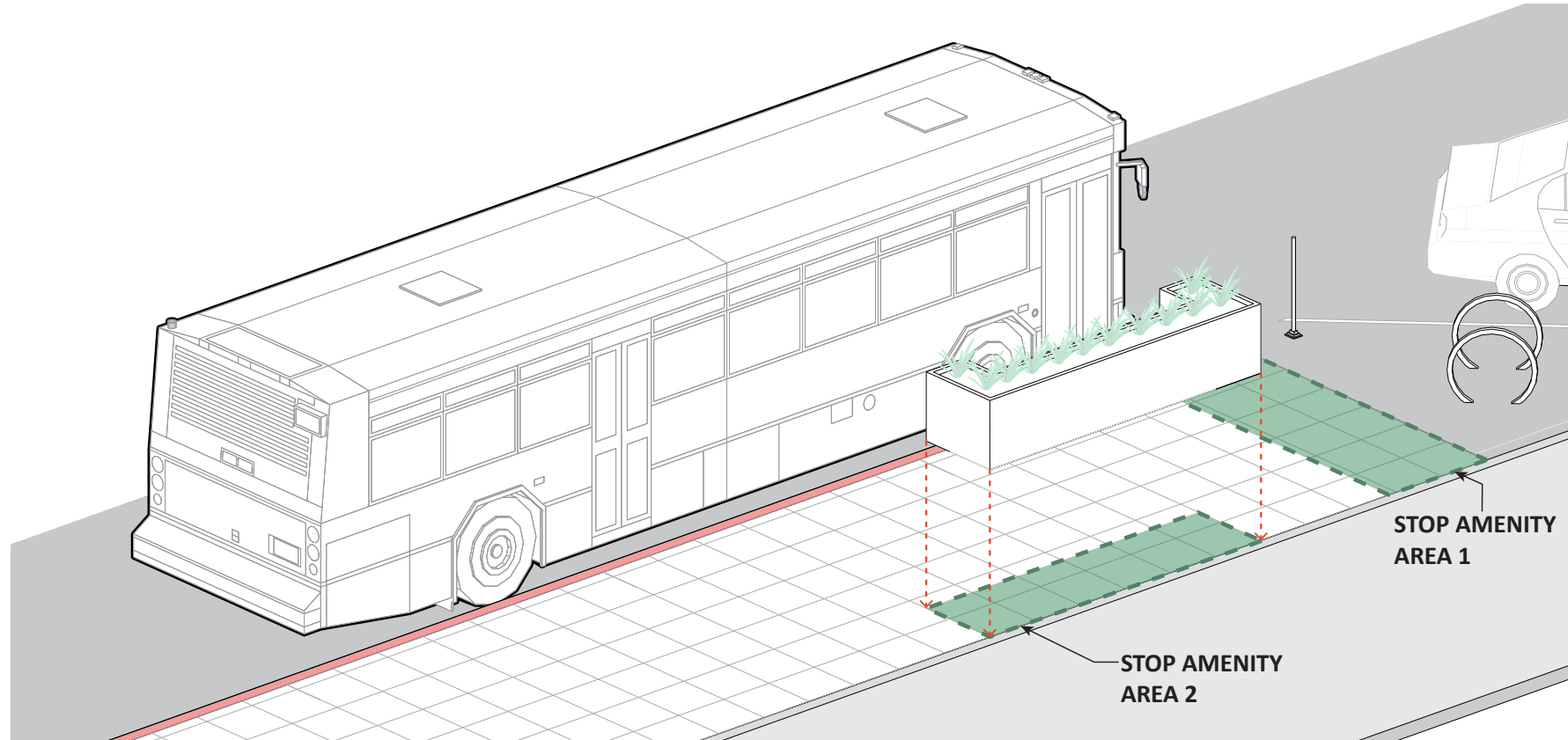
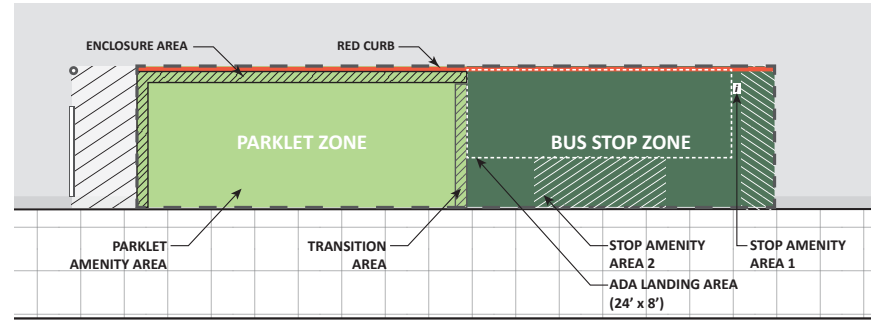

1

2

3

4

5

6

7

Overhead Structures

If desired, the Bus Stop Zone may include an overhead enclosure, such as a roof or trellis. All vertical elements associated with an overhead enclosure structure must maintain a two-foot (minimum) horizontal clearance from the roadside edge of the bus parklet (defined as the face of the red curb). All horizontal elements associated with the overhead enclosure structure must have a minimum 80-inch vertical clearance above the bus parklet platform and maintain a two-foot (minimum) horizontal clearance from the roadside edge of the bus parklet. No structural support or other vertical elements may be placed in the ADA Landing Area.

Parklet Zone

The Parklet Zone accommodates the bus parklet sponsor's desired parklet program, such as seating, tables, bicycle parking, or a range of other potential design elements. The Parklet Zone comprises the following sub-areas:

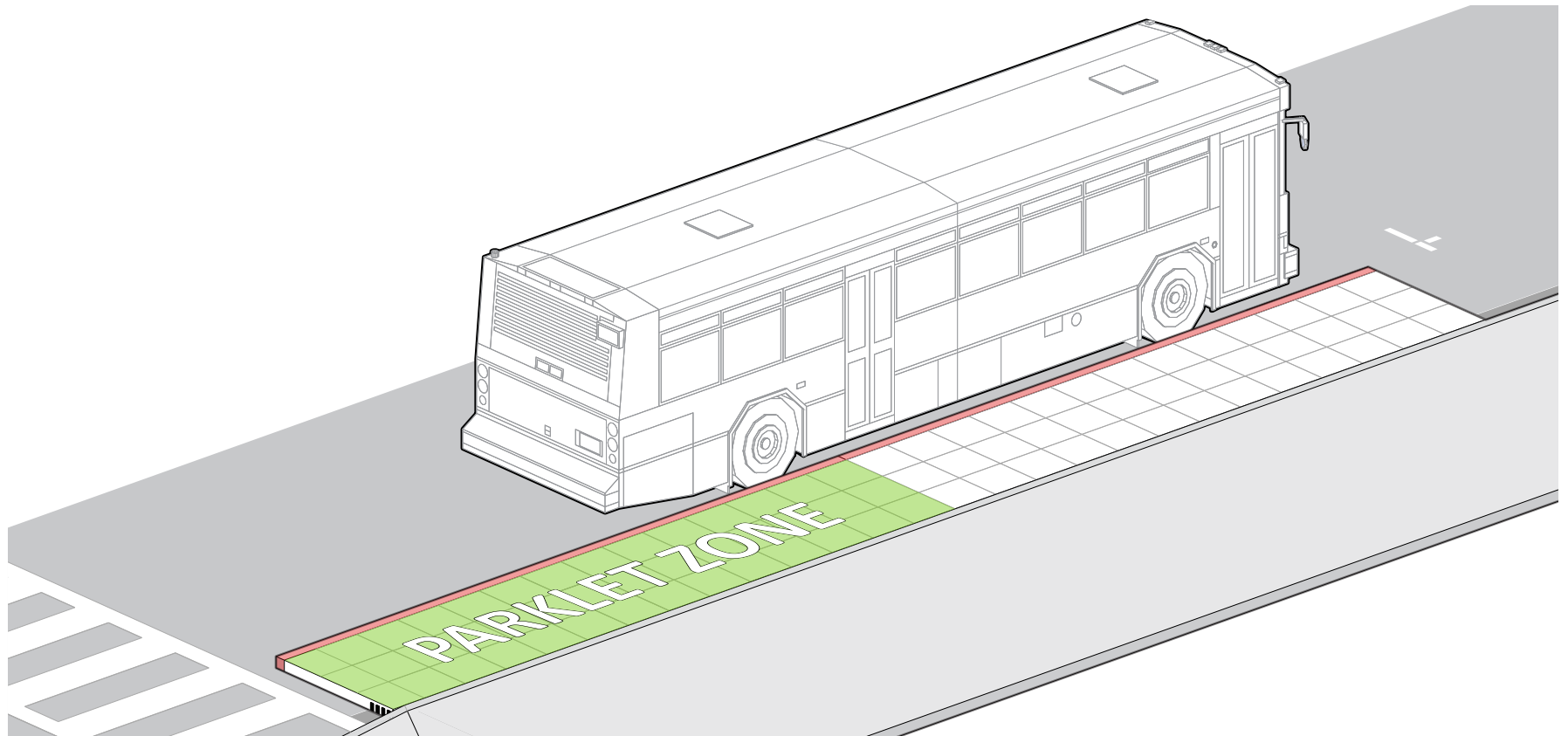

Enclosure Area

The one-foot wide Parklet Enclosure Area accommodates the required vertical edge element that provides a physical separation between the adjacent roadway and the Parklet Amenity Area. The Enclosure Area is separated from the adjacent roadway by a six-inch wide red curb that runs the length of the bus parklet. Vertical elements in the Enclosure Area can take the form of planters, railings, posts and cabling, or other design elements that provide a vertical delineation along the edge of the parklet (see Chapter 4.3 Parklet Zone Amenities).

Along the roadway-facing run of the Parklet Enclosure Area: The height of any enclosure element may range from a minimum of 36 inches to a maximum of 42 inches, including the height of any used plants.

Along the short end of the Parklet Enclosure Area: The height of any edge element may range from a minimum of 18 inches to a maximum of 42 inches, including the height of any plants. In the rare case where the Bus Stop and Parklet Zones are flipped at a near-side bus parklet location, the height of any solid enclosure element that is wider than one foot should be limited to 30 inches above the roadway surface in order to avoid obstructing

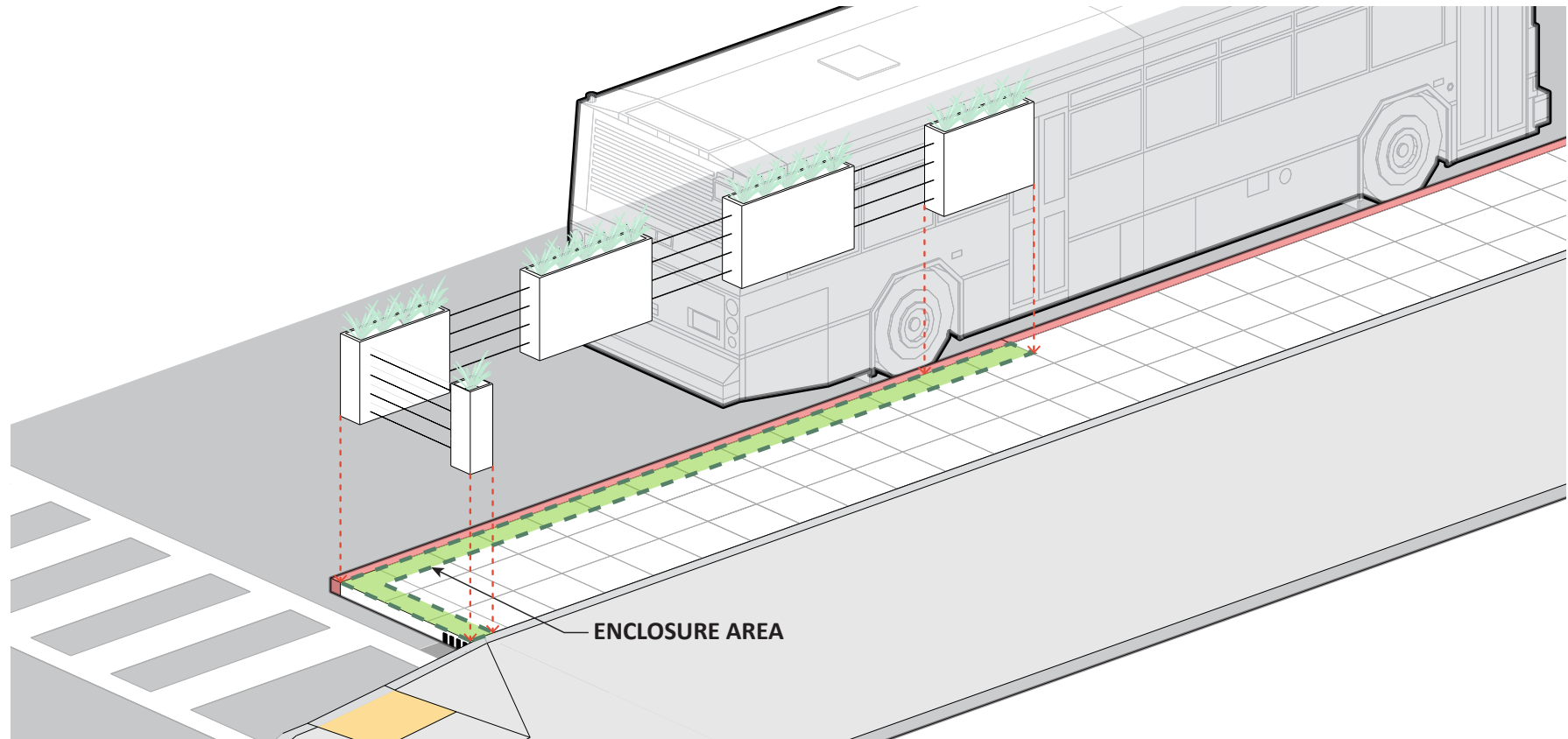

the line of sight between bus operators and drivers and pedestrians entering the crosswalk¹². The 30-inch limit includes the combined height of a planter box and plants, if these are used in the design.

In general, the edge element should be designed to maintain a visual relationship between the inside of the bus parklet and the adjacent sidewalk and the other side of the street, rather than a visually solid separation between the street and the Parklet Zone. As a rule of thumb, about 30 percent of the Parklet Enclosure Area should be designed to allow for views through the edge element. Railing openings or the spacing of cables must not exceed four inches.

Parklet Amenity Area

The Parklet Amenity Area encompasses the remaining area of the Parklet Zone and can be designed based on the needs of the bus parklet sponsor and these guidelines (see Chapter 4.3 Parklet Zone Amenities). The Parklet Amenity Area must include space accessible to persons with disabilities, including a turning space and resting space for at least one wheelchair user as well as seating space for one companion.

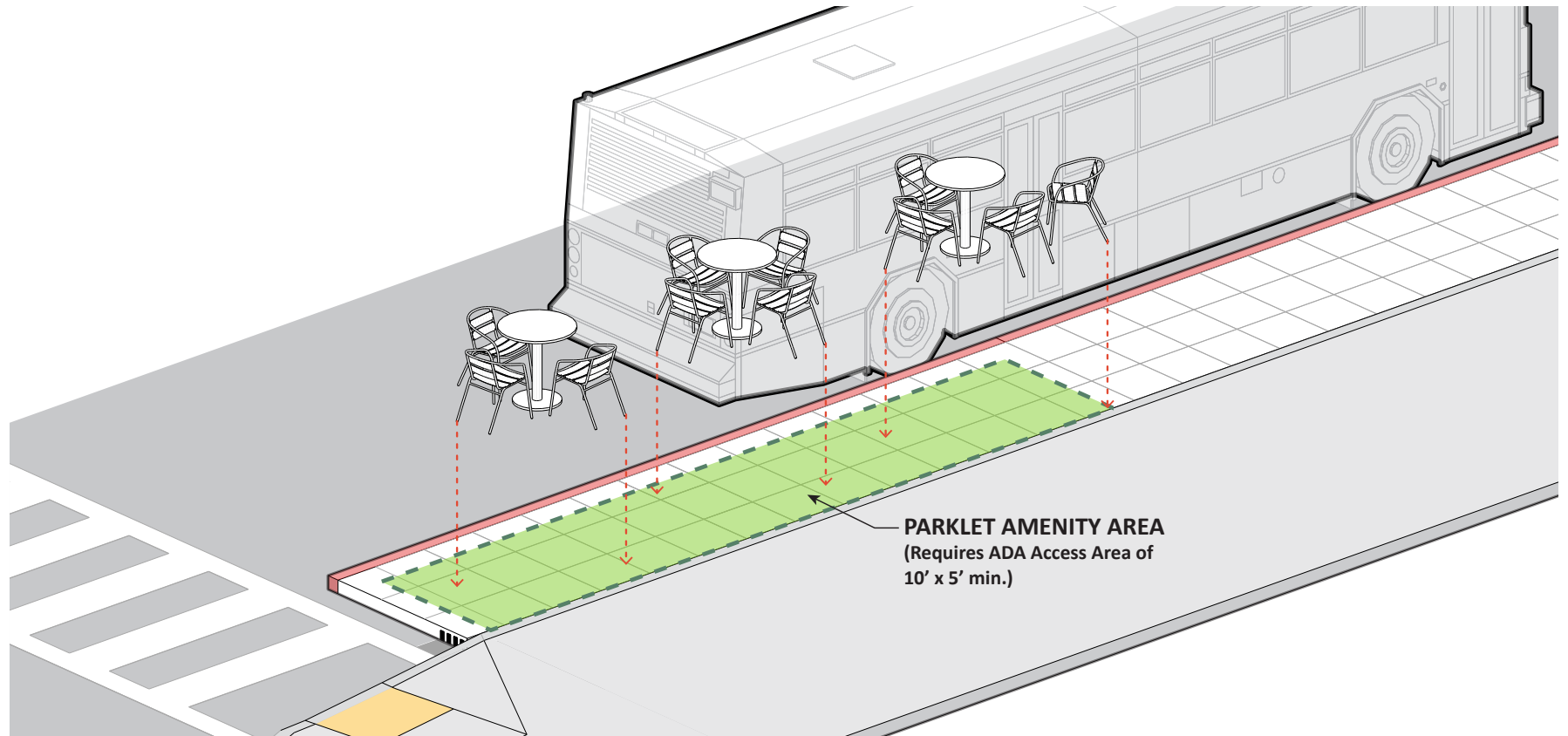

Transition Area

The one-foot wide Transition Area is located between the Parklet Amenity Area and the adjacent Bus Stop Zone. On bus parklets adjacent to parallel parking, this area should include a 36-inch wide (minimum) accessible path for a wheelchair users between the Parklet and Bus Stop Zones, whenever feasible. On wider bus parklets, a 36-inch wide (minimum) accessible path between the Parklet and Bus Stop Zones is required. In addition to the clear path of travel, a planter, seating or other design element may be placed in the Transition Area. The height and design of these elements should maintain a visual relationship between Parklet and Bus Stop Zone.

Overhead Structures

If desired, the Parklet Zone may include an overhead enclosure, such as a roof or trellis. All vertical elements associated with an overhead enclosure structure must maintain a two-foot (minimum) horizontal clearance from the roadside edge of the bus parklet (defined as the face of the red curb). All horizontal elements associated with the overhead enclosure structure must have a minimum 80-inch vertical clearance above the bus parklet platform and maintain a two-foot (minimum) horizontal clearance from the roadside edge of the bus parklet. No structural support or other vertical elements may be placed in the ADA Landing Area.

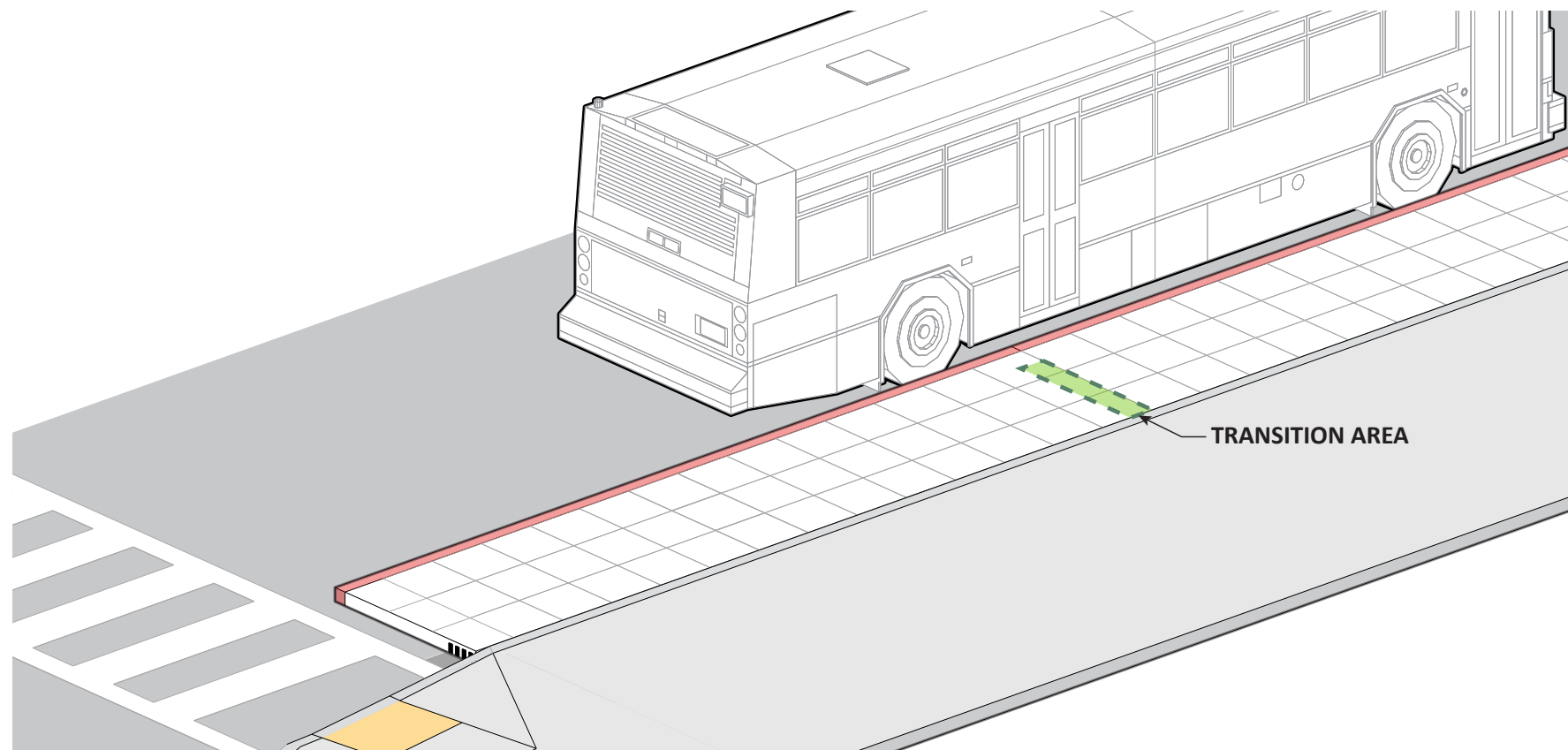

3.4 Overview of ADA Considerations

Bus parklets should be designed so that they can be used and enjoyed by persons of all ages and abilities. The bus parklet sponsor and designer are responsible for consulting all applicable regulatory standards, such as the Americans with Disabilities Act (ADA) and the California Building Code (CBC), and for meeting all required accessibility design standards. This section provides a general overview of accessibility requirements that must be observed in designing a bus parklet; note that some local jurisdictions may have requirements that exceed the minimum requirements of the Americans with Disabilities Act and the California Building Code¹³.

Accessible Path of Travel

All entries to the Parklet and Bus Stop Zones must be connected to the sidewalk by a 48-inch minimum width accessible path. Accessible paths should not pass over tree wells, unless they are covered by ADA-compliant tree grates that are field-verified to be flush with the adjacent sidewalk surface. Internal to the Parklet Zone, accessible paths must be a minimum of 36 inches wide and provide connections to the wheelchair turning and wheelchair resting spaces that are included in the design. Accessible paths within the Bus Stop Zone should be a minimum of 48 inches wide.

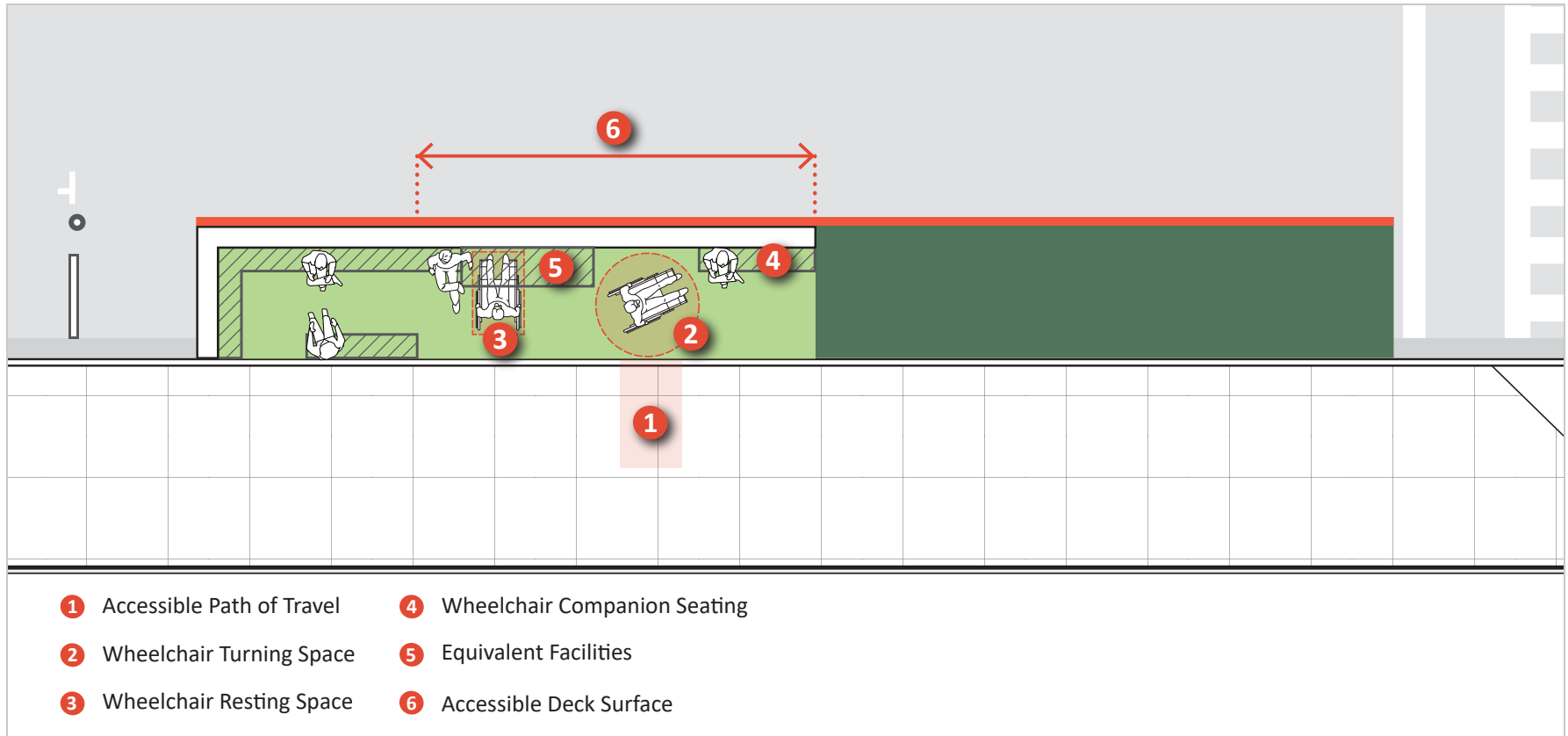

1

Accessible Entry

An accessible bus parklet entry is the location where an accessible path crosses from the sidewalk onto the platform surface. Parklet entries should be readily identifiable. Each accessible entry is considered part of the accessible path and must be at least 48 inches wide, free of horizontal surface gaps larger than half an inch, free of vertical offsets larger than one quarter of an inch, and clear of obstructions. Accessible entries should be located where sidewalk and curb have the least amount of running slope.

2

3

Accessible Platform Surface

All areas of the accessible platform surface must be level. This includes the entire ADA Landing Area, the wheelchair turning space and the wheelchair resting space. The maximum cross slope (perpendicular to the sidewalk or curb) of an accessible platform surface must not exceed 1:48 (two percent). The accessible platform surface's maximum running slope (parallel to the curb) must not exceed 1:48 (two percent)

4

For other areas of the platform surface, the running slope may not exceed 1:20 (five percent). If the platform surface includes any level changes, the different levels must be connected by an ADA-compliant ramp with a running slope not to exceed 1:20 (five percent) or served by separate accessible bus parklet entries.

5

6

When stairs or ramps are permitted, they must meet all building code requirements for rise, run, width, handrails, and contrasting stair striping for the visually impaired.

7

Wheelchair Turning Space

A wheelchair turning space for 360-degree turning movements of a wheelchair must be provided within the Parklet Zone of the bus parklet. A maximum of 12-inches of the turning space may overlap onto the adjacent curb and sidewalk. The 360-degree turning space in the Bus Stop Zone is included in the required 24' x 8' ADA Landing Area.

Wheelchair Resting Space

At least one wheelchair resting space must be provided within the Parklet Zone of the bus parklet. The wheelchair resting space requires a clear floor area on the platform of 30 x 48-inches. This space may overlap with the wheelchair turning space by 24 inches (maximum) in any orientation.

Wheelchair User Companion Seating

If the bus parklet design includes any fixed seating, it should also accommodate seating for the companion of a wheelchair user. Whenever feasible, the wheelchair resting space should permit shoulder-to-shoulder alignment adjacent to one side of the fixed seat.

Establishing Equivalent Amenities

If the bus parklet design includes any amenities such as tables (built-in or movable), counters, or rails for the placement of beverages, the design should accommodate at least one of each feature to be wheelchair accessible and to meet all applicable ADA requirements for height and approachability¹⁴.

Other Access Issues

Other ADA and CBC guidance and requirements related to access should also be provided for, such as access to posted bus schedules and transit maps, vertical clearances from overhanging objects, etc.

4. Bus Parklet Design Elements



The overall experience of transit passengers and other users of the bus parklet will strongly depend on the functional, physical, visual qualities and characteristics of the design elements placed in the functional zones and sub-areas of the bus parklet discussed in the previous chapter. The combination and required and optional elements and their specific design and placement may vary based on the bus parklets urban context, existing conditions, and programming and design preferences and needs of the bus parklet sponsor. This chapter outlines the desired design and material performance characteristics for the most common design elements of a bus parklet and amenities. Additional elements may be considered on a case-by-case basis after review by AC Transit and the local jurisdiction.

This chapter discusses the following design elements:

- Bus Parklet Platform and Platform-Sidewalk Transition
- AC Transit Bus Sign (Flag) and Pole
- Seating
- Planter Boxes and Planting
- Railings
- Lighting
- Bicycle parking
- Other Bus Parklet Design Elements

4.1 Bus Parklet Platform and Platform-Sidewalk Transition

1

The parklet platform is the most fundamental design element of any parklet structure. It forms the structural base for all other parklet improvements, includes the transition between bus parklet and sidewalk, facilitates proper drainage of stormwater runoff from the platform surface as well as along the existing gutter, and provides the access from the sidewalk to the bus. Although parklet designers from around the country have developed many different approaches to the design and detailing of platforms for regular parklets, the design of bus parklet platforms requires the following additional design considerations:

2

3

- A curb detail along the roadway-side length of the bus parklet, that establishes a platform edge sturdy enough to withstand the occasional touching and bumping by bus tires as the bus is pulling parallel to the Bus Stop Zone.
- A platform surface that is particularly durable so that it can withstand the wear and tear caused by passenger boarding and alighting activities.

4

- A platform surface that drains collecting stormwater quickly to allow use of the bus parklet for bus boarding/alighting even during rain fall.
- A platform surface that achieves ADA compliance in terms of conformance with required maximum longitudinal and cross slopes and a smooth platform-sidewalk transition for the path of travel to the ADA bus loading area.

The platform of the pilot bus parklet on Solano Avenue (*see Appendix B*), located in the City of Albany, California, addresses these additional design considerations by including the following:

- A steel frame, custom fitted to local grades and required slopes for the platform surface and held in place by a limited number of bolt and epoxy connections to the roadway.
- A platform surface, consisting of a grid of concrete pavers brought into conformance with required longitudinal and cross slopes by leveling devices that are part of the suspended pavement/platform system.

5

6

7

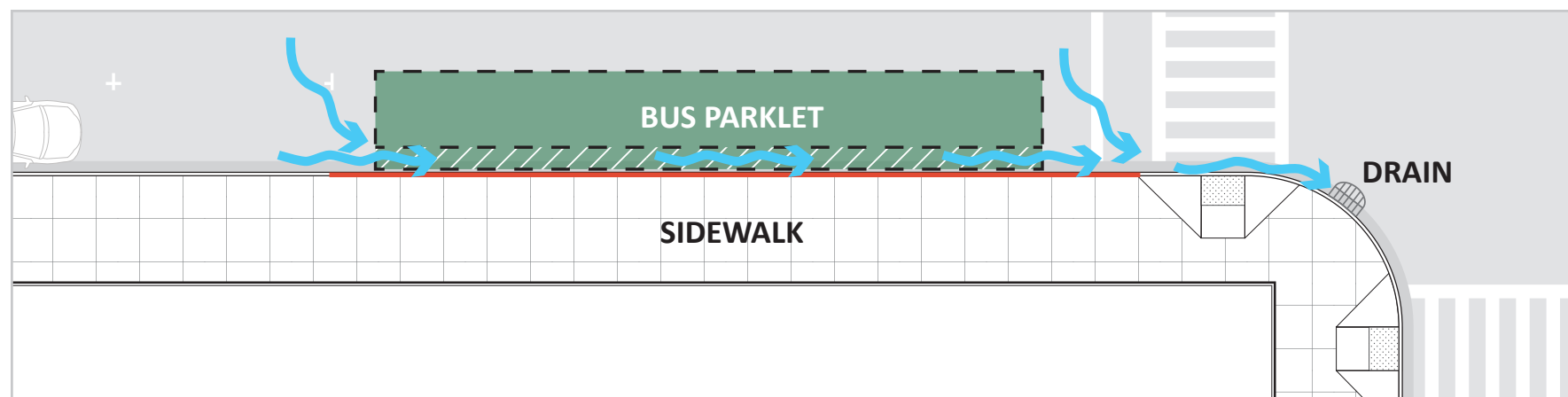

Drainage

- 1
- 2
- 3
- 4
- 5
- 6
- 7

- A six-inch wide, concrete curb (painted red), installed along the length of the roadside edge of the platform to protect other parts of the bus parklet from direct contact with the tires of the bus.
- A suspended paving system that:
 - Drains stormwater runoff from the platform surface through ADA compliant (<1/4 inch) gaps between the suspended concrete pavers.
 - Allows the flow of stormwater runoff under the suspended pavement system to the existing gutter and the nearest storm drain inlet.
- A grate, covering the up-slope opening between platform and gutter to let stormwater runoff continue its flow along the gutter while preventing trash from getting washed into and trapped under the platform.
- A platform-sidewalk transition, consisting of a steel ledger that is attached to the curb face by bolts and epoxy and designed to establish a tight and even surface transition between the top of the curb and the row of suspended platform pavers immediately adjacent to the curb.
- Removable pavers (with holes for removal with a tool), facilitating access to utility covers located under the platform and to inspect and clean out the gutter as needed.

Other types of platform framing and surfacing are acceptable as long as they address the aforementioned design considerations, are structurally sound, and meet approval by the local jurisdiction.

All connections between platform components, such as a steel frame, ledger, or edge curb that and the existing roadway and curb face that involve drilling, bolting, or gluing to their surfaces require approval by the respective local jurisdiction. The bus parklet sponsor will be responsible for the repair of the roadway and curb surface after the bus parklet is removed as specified by the local jurisdiction. AC Transit may support the parklet sponsor in this effort on a case-by-case basis.

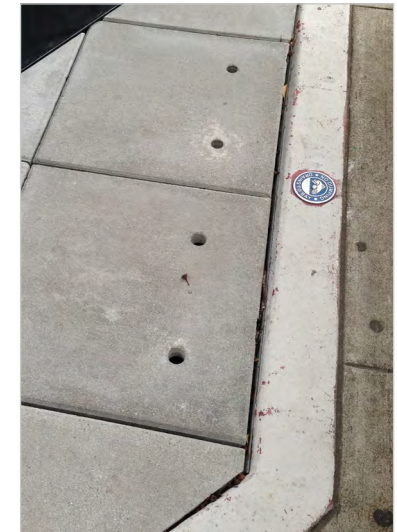

Removable pavers provides access to utility covers under the platform at the Pilot Bus Parklet in Albany



Gutter grate and Drainage treatment at the Pilot Bus Parklet in Albany

4.2 Bus Stop Zone Amenities

AC Transit Bus Sign (Flag) and Pole

A bus sign (flag) and pole must be included in every bus parklet. Size, content, and design of the sign must follow AC Transit's standard specifications. The sign, but not the pole, will be provided by AC Transit. The pole should also follow AC Transit's specifications unless a custom design is needed to integrate the pole and sign with the railing or planter element that delineates the front-end of the bus parklet in Bus Stop Amenity Area 1. The sign pole and sign must be located two feet clear of the roadside edge of the platform.



AC Transit Bus Sign (Flag) and Pole on the Pilot Bus Parklet in Albany

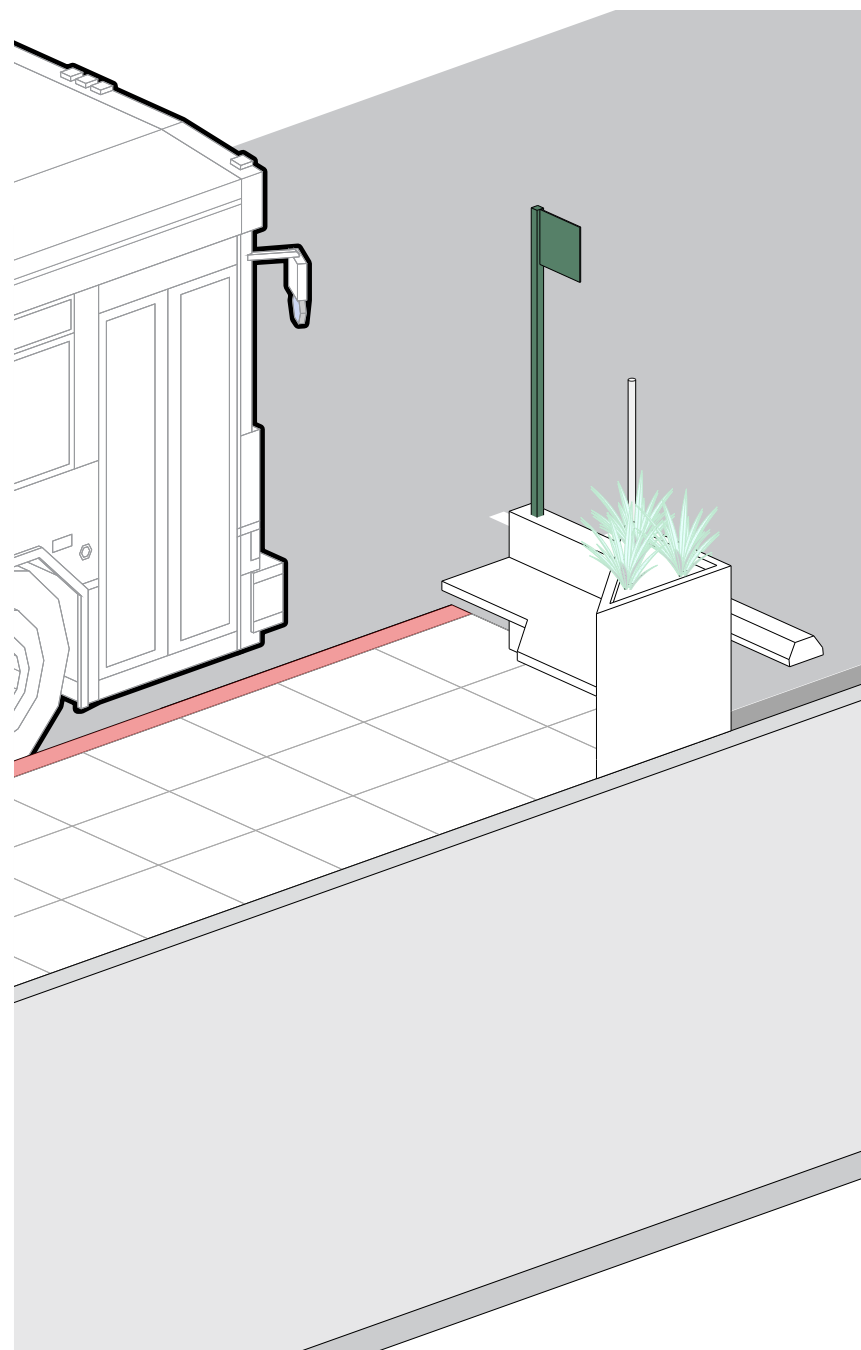

1

2

3

4

5

6

7

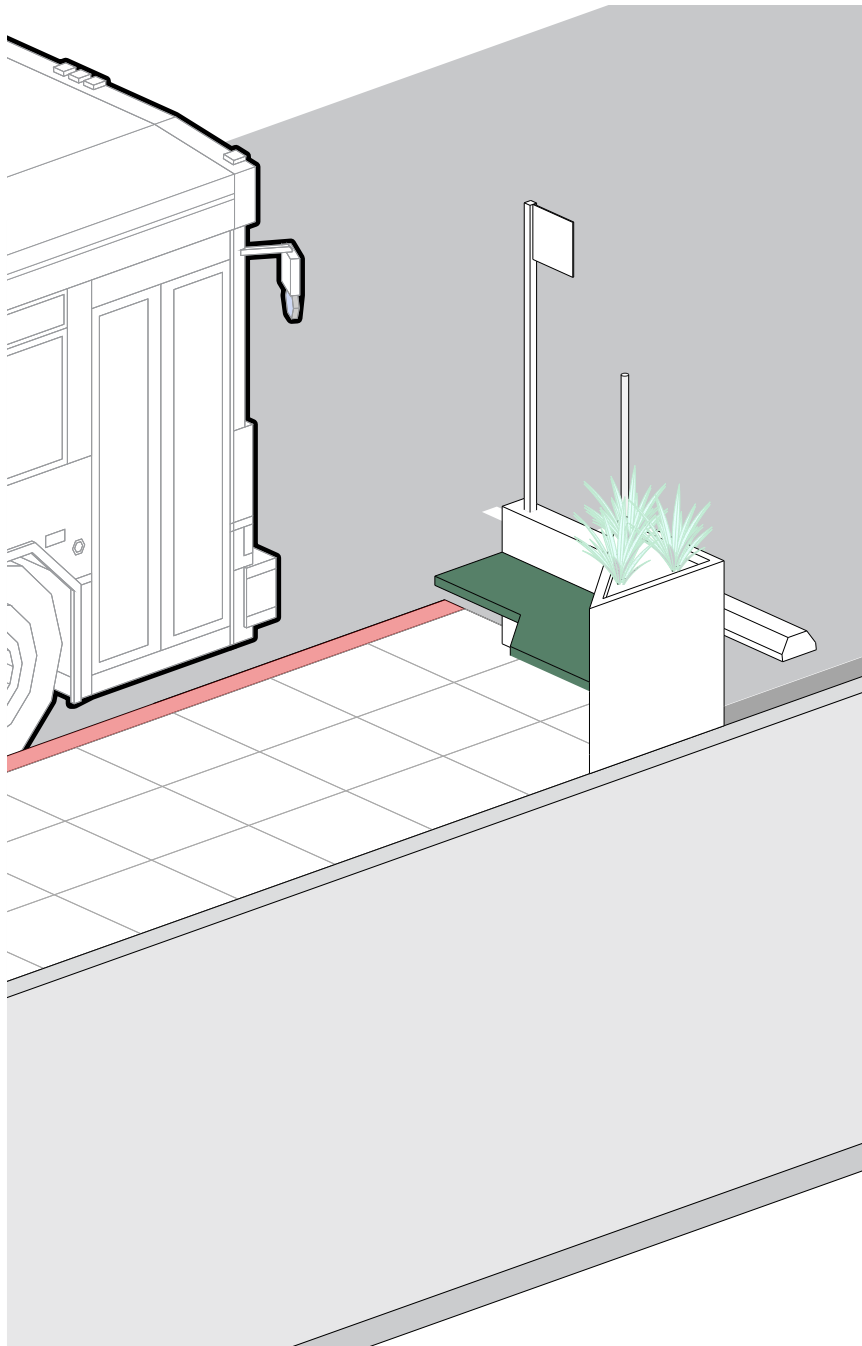

Seating

Seating should be incorporated into the design of Bus Stop Amenity Area 1. Any horizontal surface designed for seating, should maintain a two-foot minimum clearance from the roadside edge of the platform. On bus parklets integrated into angled or perpendicular parking, seating may also be located in Bus Stop Amenity Area 2 as long as six-foot wide, straight clear paths of travel are provided on either side of the seating element between the bus doors one and two and the sidewalk. Seating in either Bus Stop Amenity Area may take various forms, such as stand-alone, commercially available benches or custom seating elements that are integrated with the design of railings, planter boxes, or the platform surface. Seating must be secured to the parklet using bolts or other appropriate measures. Moveable furnishings such as tables, chairs, and benches are not allowed in the Bus Stop Zone of the parklet.



Seating on the Pilot Bus Parklet in Albany

Planter Boxes and Planting

The use of landscape plants in planter boxes in the Bus Stop Zone is encouraged as long as the sponsor agrees to take on maintenance of the plants along with those used in the Parklet Zone. If the Parklet Zone does not include landscaped planters, the Bus Stop Zone should also omit their use. In the Bus Stop Zone, the opportunity for the placement of planter boxes is limited to the space in Amenity Areas 1 and 2. In selecting and maintaining plants, the sponsor is encouraged to follow guidelines for Bay-friendly Landscaping¹⁵. In general, plants should be drought-tolerant and easy to maintain. Planter boxes and plants must meet the height limits discussed under Bus Parklet Functional Zones (see Chapter 3.3 Bus Parklet Functional Zones). The placement of small trees is not permitted in the Bus Stop Zone.



Planter Boxes and Planting on the Pilot Bus Parklet in Albany

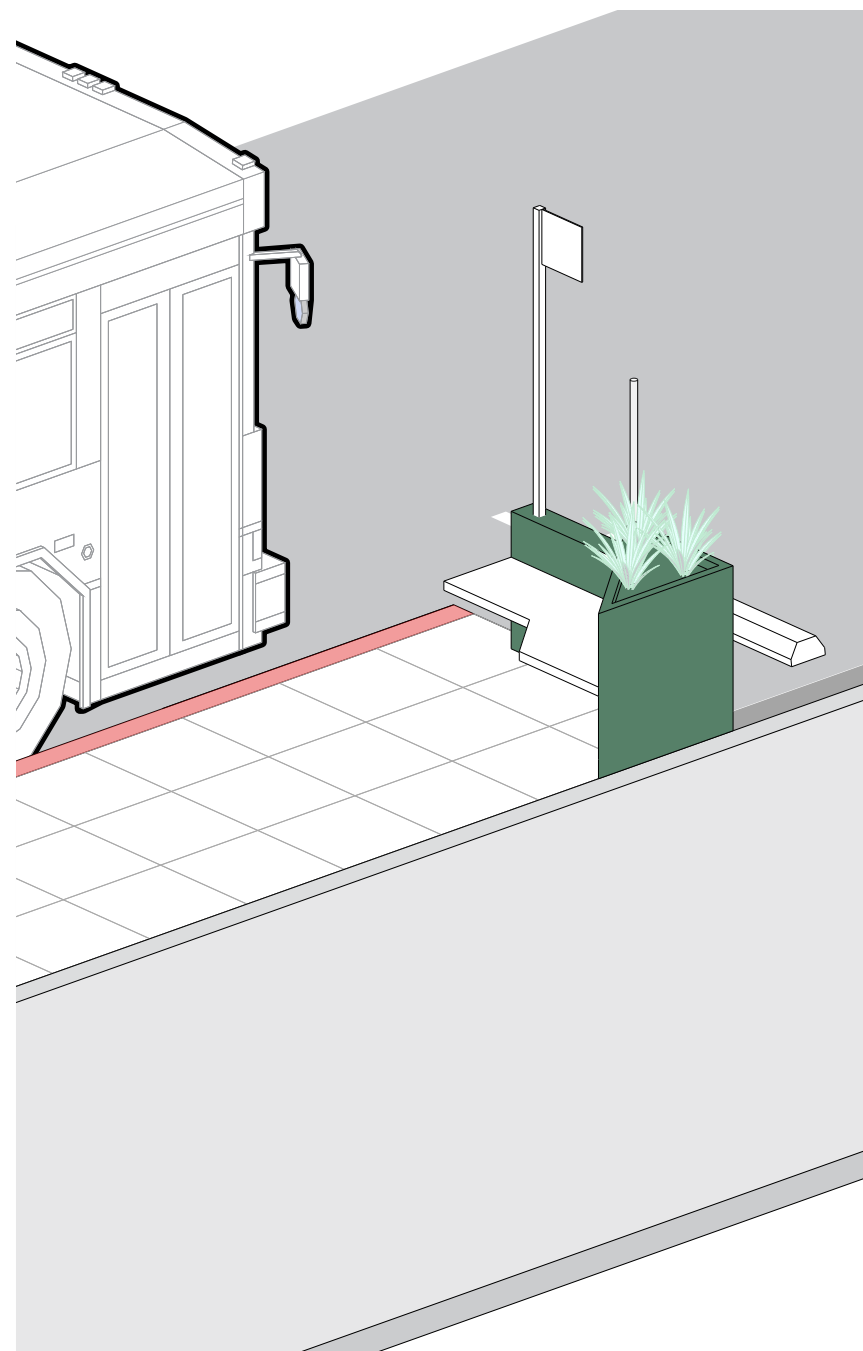

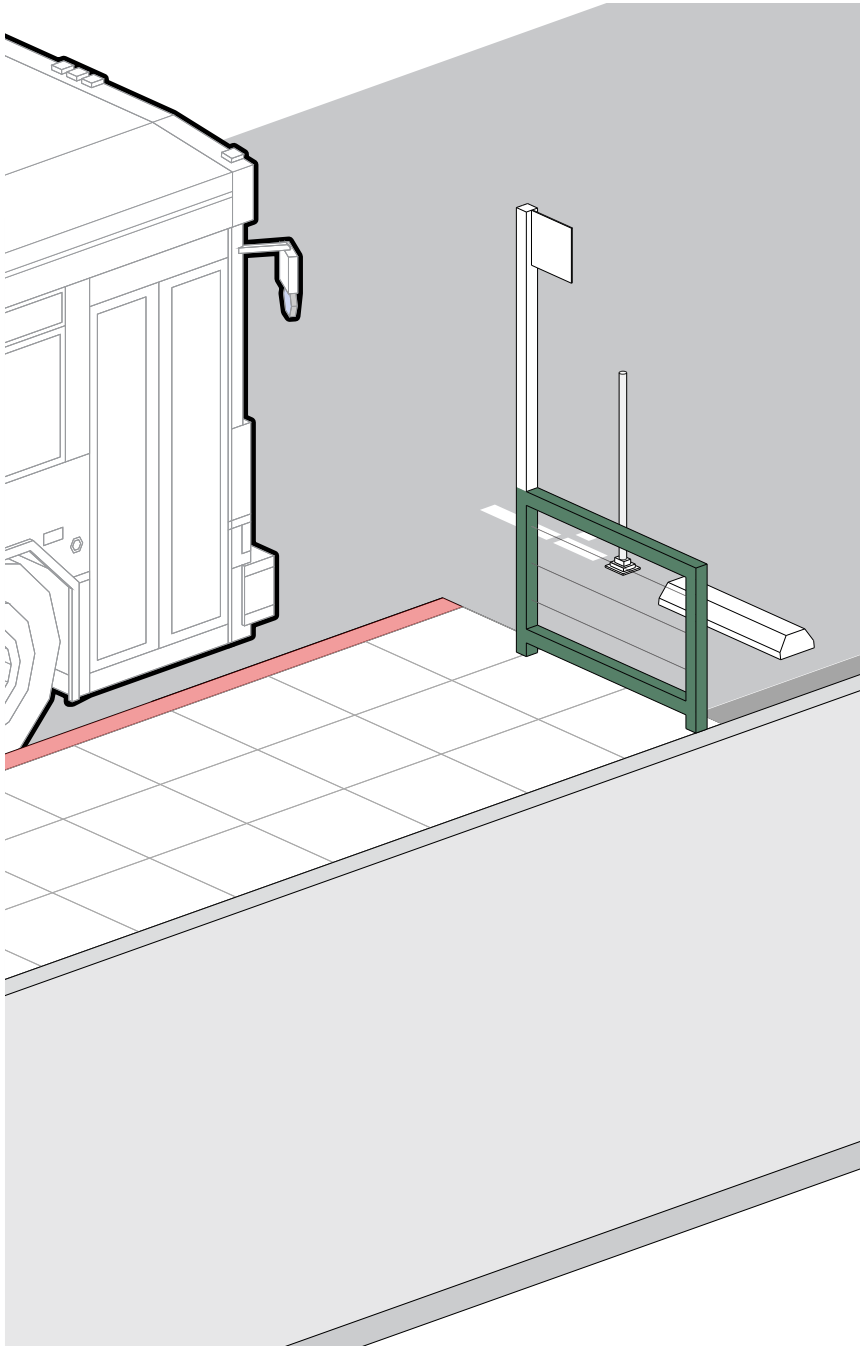

Railing

Where the vertical edge in the Enclosure Area is established by using a form of railing – whether consisting of posts and panels or posts and cables – the overall design of the railing element should allow for a visual connection between the Bus Stop Zone and other parts of the street in order to promote a sense of integration and openness to access the bus parklet. The railing element must be between 36 inches to 42 inches high with openings of no more than 4 inches (*also see Chapter 3.3 Bus Parklet Functional Zones*).

Lighting (Optional)

The inclusion of lighting elements into the Bus Stop Zone is strongly encouraged in cases if the bus parklet sponsor is also planning to include lighting in the design of the Parklet Zone. Lighting involves additional permitting with the respective local jurisdiction. Lighting elements should be selected or designed to avoid undue glare that may negatively impact bus operators and other drivers, bicyclists, pedestrians or residents in nearby homes or apartments. The sponsor may consider using alternative sources of energy such as solar-powered lighting to avoid securing a separate electrical permit.

1

2

3

4

5

6

7

4.3 Parklet Zone Amenities

Seating

Seating elements may be placed in the Parklet Amenity Zone based on the sponsor's programmatic goals for the parklet. The seating can consist of stand-alone, commercially available benches or custom seating elements that are integrated with the design of planter boxes or other vertical elements. Seating may also be integrated with railings or planter boxes used as design elements in the Enclosure Area. Moveable furnishings such as

tables, chairs, or benches are allowed in the Parklet Amenity Zone as long as their design and color schemes are different from furnishings used in association with the sponsor's business activities¹⁶.

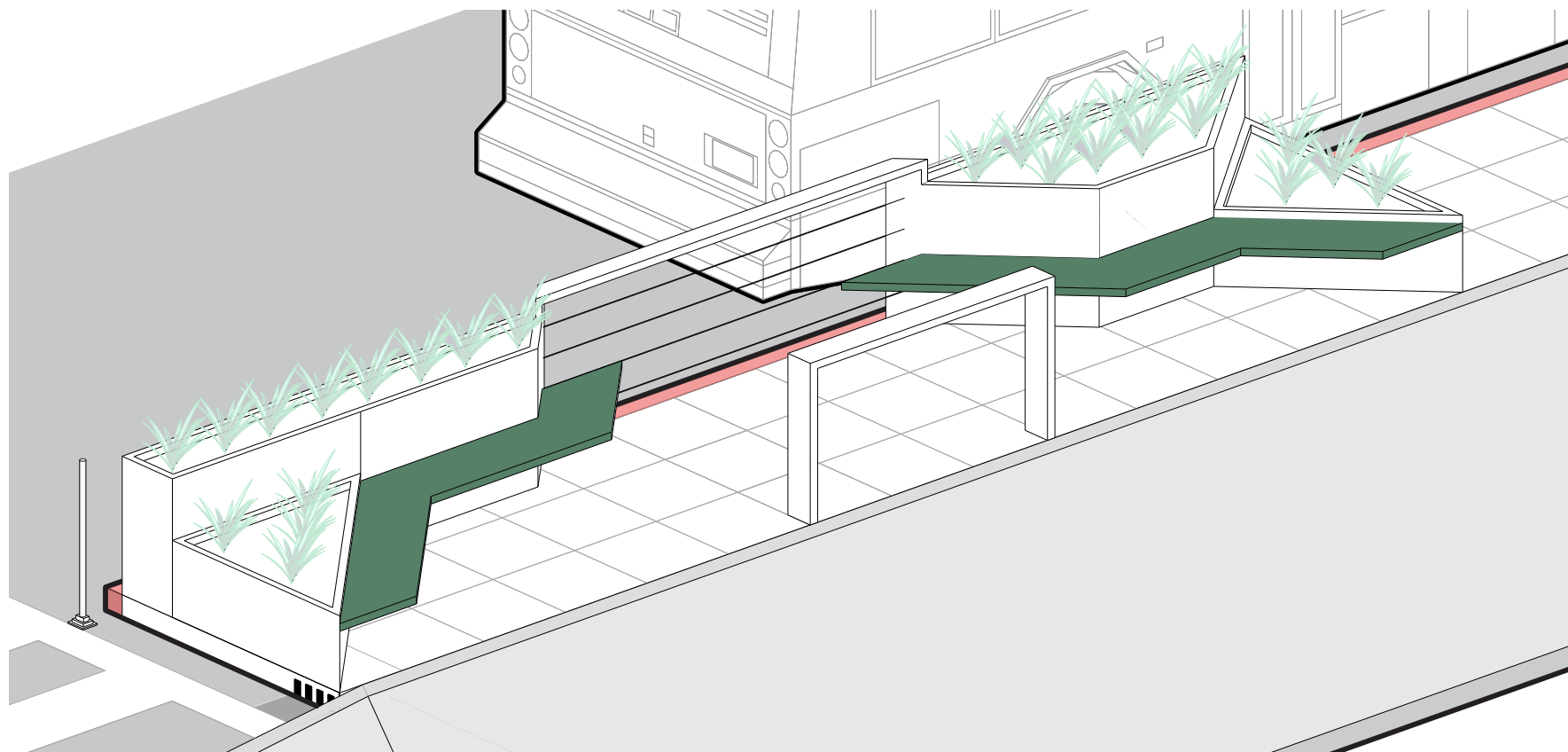

Planter Boxes and Planting

The use of landscape plants in planter boxes in the Parklet Zone is encouraged. In the Parklet Zone, planter boxes may be used as a design element in all three sub-areas (Enclosure, Amenity, and Transition Area). The selection and maintenance of plants should follow the guidelines for Bay-friendly Landscaping originally developed by StopWaste.org¹⁷. In general, plants should be drought-tolerant and easy to maintain. Planter boxes used in the Enclosure Area must meet the height and width limits discussed under Bus Parklet Functional Zones (*see Chapter 3.3 Bus Parklet Functional Zones*). If small trees are located within the Parklet Zone, they must not obstruct sightlines between the bus operator and the Bus Stop Zone.

Railing

Where the vertical edge in the Enclosure Area is established by using a form of railing – whether consisting of posts and panels or posts and cables – the overall design of the railing element should allow for a visual connection between the Parklet Zone and other parts of the street in order to promote a sense of integration and openness to access the bus parklet.

The railing element must be between 36 inches to 42 inches high with openings of no more than 4 inches (*see Chapter 3.3 Bus Parklet Functional Zones*).

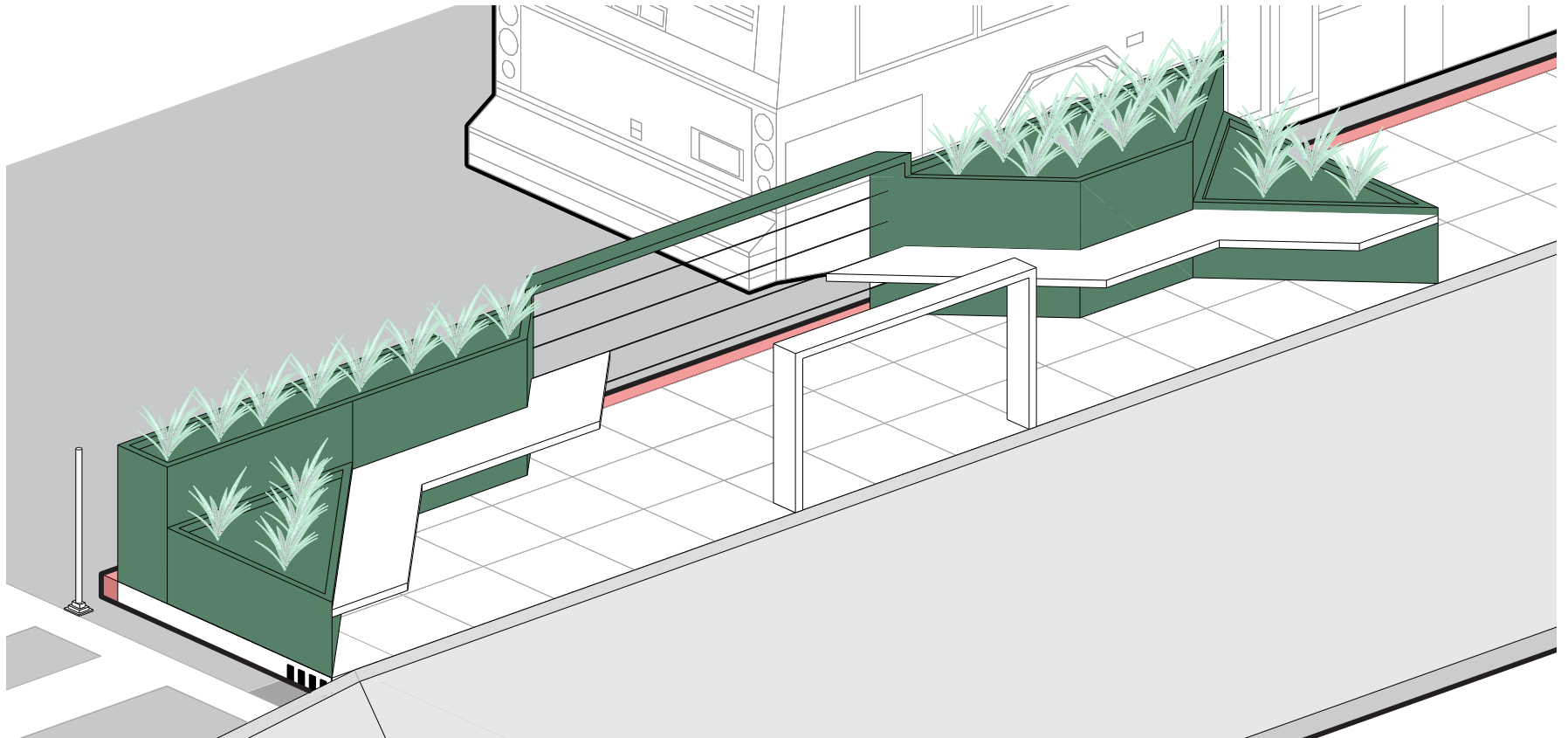

Lighting

The inclusion of lighting elements into the Parklet Zone is encouraged but involves additional permitting with the respective local jurisdiction. Lighting elements should be selected or designed to avoid undue glare that may negatively impact bus operators and other drivers, bicyclists, pedestrians, or residents in nearby residences. The bus parklet sponsor may consider using alternative sources of energy such as solar-powered lighting to avoid securing a separate electrical permit. If lighting elements are used in the Parklet Zone, they should be located such that lighting is also provided to the Bus Stop Zone.



Example of parklets with Lighting elements

Bicycle Parking

Bicycle parking in the Parklet Zone or adjacent to the parklet should be strongly considered as a programmatic element. Bicycle parking may consist of stand-alone bicycle racks located in the Parklet Amenity Zone, custom racks integrated into the overall design of the bus parklet structure, or bicycle racks placed in space available on the sidewalk or in bulb-outs adjacent to the bus parklet. If an additional 15 feet of space is available in the parking lane adjacent to the bus parklet, this space should be considered as an opportunity for installing an on-street bicycle corral. The placement of bicycle parking in areas outside of the limits of the bus parklet should be closely coordinated with the respective local jurisdiction.



Example of parklets with Bicycle Parking

4.4 Other Bus Parklet Design Elements

Soft-Hit Posts

The prototypical layouts in Chapter 5 show the locations in which soft-hit posts are to be installed. The intent of these vertical markers is to alert drivers to the outside edge of the overall spatial envelope occupied by the bus parklet. The reflective tape at the top of the posts provides an enhanced night time visibility of the posts. Soft-hit posts should be three feet tall, white in color, and meet the specifications for a Safe Hit Type 2 Guide Post. The posts may be surface mounted with a pink lock base or using a butyl adhesive pad or 10 oz. epoxy kit.



Example of a Soft-Hit Post

On streets with one travel lane in each direction, a bus stopped at the bus parklet will temporarily occupy the single available travel lane adjacent to the parklet. In order to prevent vehicles from going around the stopped bus by entering the travel lane going in the opposite direction, a series of yellow soft-hit posts should be placed along the center line of the roadway. These should extend beyond the back of the bus in its typical stopping location.



Soft-Hit Post at the Pilot Bus Parklet in Albany and Yellow Soft-Hit Posts along the centerline of the roadway

Wheel Stops

The prototypical layouts in Chapter 5 show locations in which wheel stops are to be installed to demarcate the outside edge of the buffer area between the bus parklet and the nearest parking stall and to prevent vehicles from maneuvering too close to the bus parklet structure. The wheel stops should be three-foot long, made of black rubber with yellow stripes, and be installed one foot from the curb. The wheel stops should be secured using bolts or other types of connections acceptable to the respective local jurisdiction.



Example of Wheel Stops

Public Parklet Signs

It is recommended that the bus parklet sponsor affix two “Public Bus Parklet” signs in conspicuous locations on the bus parklet structure. The signs should indicate the bus parklet’s hours of operation, include a no smoking symbol, and that all parts of the parklet are accessible to the public at all times during posted hours. The format and design of the sign should meet ADA requirements for signage and placards. With exception of the bus sign (flag), no other signs, logos, or advertising of any kind should be placed on any part of the bus parklet, unless specifically permitted by the respective local jurisdiction.



Public Parklet Signs on the Pilot Bus Parklet in Albany

Future Consideration of Transit Shelters

The standard shelters used at AC Transit’s bus stops are not owned by the transit agency but rather by a media agency that provide the shelters and their maintenance in exchange for advertising space included in the shelter design. While integrating the advertising company’s shelters into the bus parklet concept presents an opportunity for adding weather protection to a bus parklet, it is not included in the design guidance of the Bus parklet Study as it requires a detailed exploration of what conditions would need to be met for the media agency to agree to its shelters’ inclusion in a bus parklet from a legal perspective and with regard to structural calculations.

In the event the bus parklet concept proves to be successful with sponsors and bus patrons, AC Transit should consider further exploring the incorporation of its media agency’s shelters into bus parklets.

Table 4.1 summarizes required and optional bus parklet amenities and functional elements.

TABLE 4.1: BUS PARKLET AMENITIES AND FUNCTIONAL ELEMENTS		
BUS STOP ZONE AMENITIES	PARKLET ZONE AMENITIES	OTHER BUS PARKLET ELEMENTS
AC Transit Bus Sign (Flag) and Pole*	Seating	Soft-Hit Posts*
Seating	Railing	Wheel Stops*
Railing	Planter Boxes and Planting	Public Parklet Sign*
Planter Boxes and Planting	Lighting	Transit Shelter**
Lighting**	Bicycle Parking	
* Required ** Optional		



1

2

3

4

5

6

7

This page intentionally left blank

5. Bus Parklet Site Design Prototypes



This chapter provides an overview of critical dimensions and basic bus parklet layouts for what are expected to be the most common conditions for stop locations, on-street parking, and curb configurations along urban streets and corridors that along which the implementation of bus parklets will likely occur. The following prototypical bus parklet layouts are covered here in greater detail:

1. Parallel On-Street Parking – Near-side Stop
2. Parallel On-Street Parking – Far-side Stop
3. Angled or Perpendicular On-Street Parking – Near-side Stop
4. Angled or Perpendicular On-Street Parking – Far-side Stop

In addition, an overview of dimensions for setbacks and other site related parameters are also provided for bus parklets located:

1. At street corners with Bulb-Outs and Parallel, Angled or Perpendicular On-Street Parking (Near-side and Far-side Stops)
2. At Mid-block locations with Parallel, Angled or Perpendicular On-Street Parking (Near-side and Far-side Stops – relative to crosswalk)
3. At Mid-block locations with Bulb-Outs and Parallel, Angled or Perpendicular On-Street Parking (Near-side and Far-side Stops – relative to crosswalk)
4. At Far-side Stops with Parallel, Angled or Perpendicular On-Street Parking and reversed Parklet and Bus Stop Zones (with and without adjacent bulb-out)

5.1 Prototypical Bus Parklet Layouts and Dimensions for Parallel On-Street Parking

The recommended minimum length for a bus parklet is 68 feet for near-side locations and 60 feet for far-side locations. The width of a bus parklet equals the width of the existing parallel parking lane minus one-foot setback from the adjacent travel lane, typically between six and seven feet. The requirement of a 24 feet x 8 feet ADA Landing Area (see Chapter 3) requires a one- to two-foot encroachment onto the adjacent sidewalk area.

This bus parklet configuration is therefore only recommended for locations with a minimum sidewalk width of 10 feet in order to maintain a clear eight-foot wide clear through zone for pedestrian movement. Any existing vertical obstructions located in the area into which the ADA Landing Area encroaches must be relocated.

Bus Parklet at a Near-side Stop: 3D View

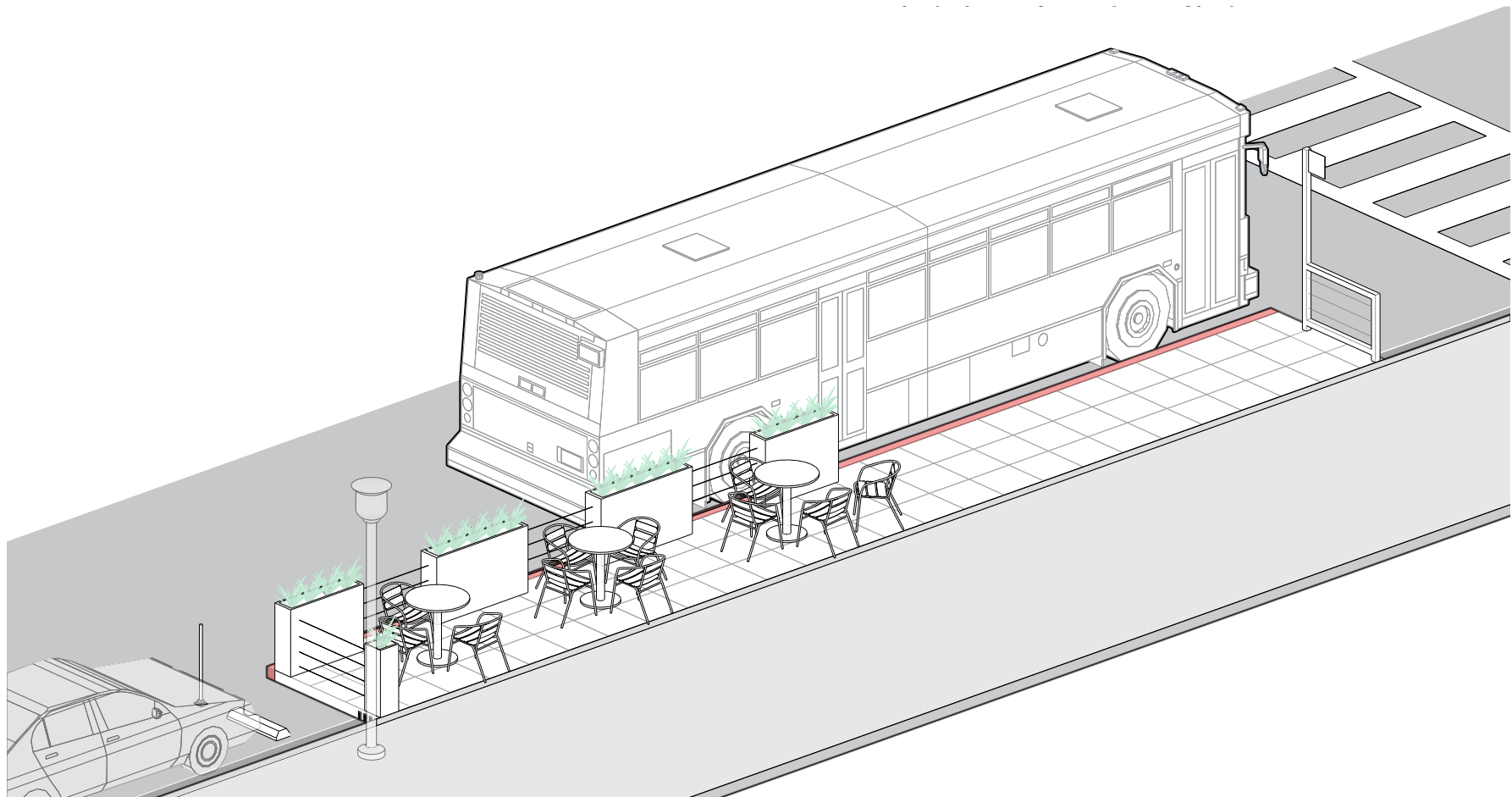

Bus Parklet at a Near-side Stop: Plan View

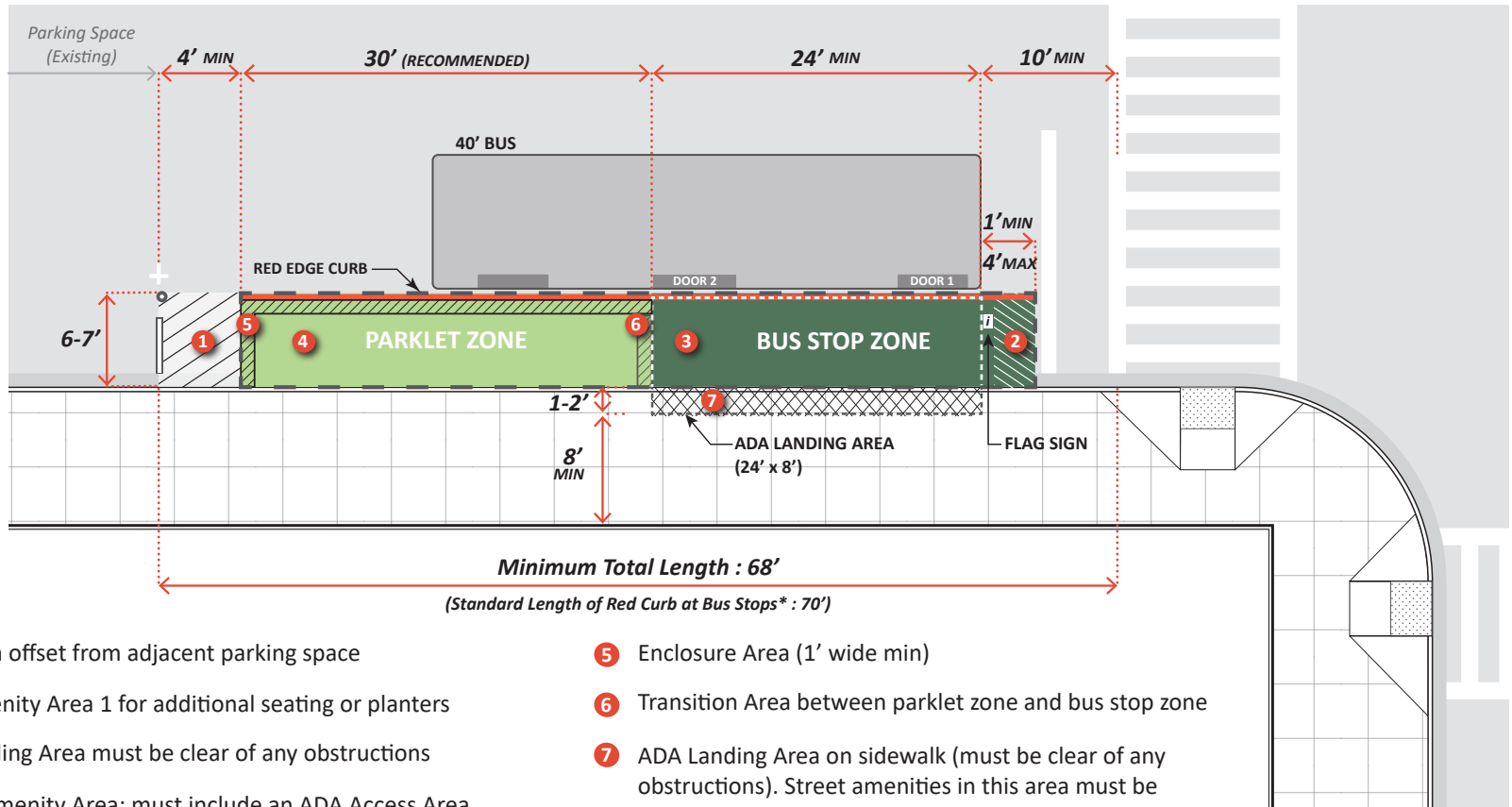

- 1 Minimum offset from adjacent parking space
- 2 Stop Amenity Area 1 for additional seating or planters
- 3 ADA Landing Area must be clear of any obstructions
- 4 Parklet Amenity Area; must include an ADA Access Area (10' min x 5')

- 5 Enclosure Area (1' wide min)
- 6 Transition Area between parklet zone and bus stop zone
- 7 ADA Landing Area on sidewalk (must be clear of any obstructions). Street amenities in this area must be relocated

* Developed from guidance per AC Transit's handbook: *Designing with Transit (2004)*

Bus Parklet at a Far-side Stop: 3D View

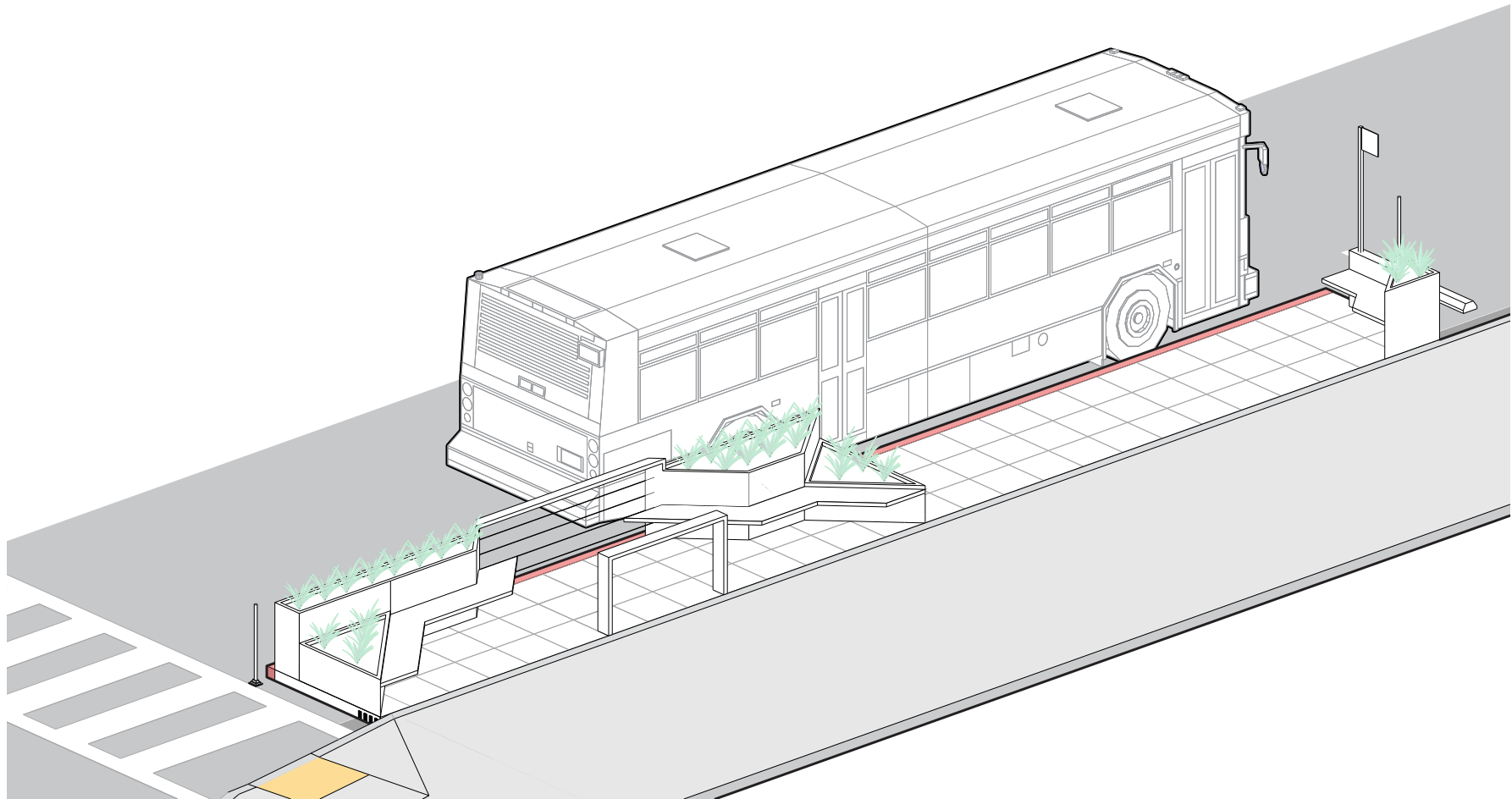

1

2

3

4

5

6

7

Bus Parklet at a Far-side Stop: Plan View

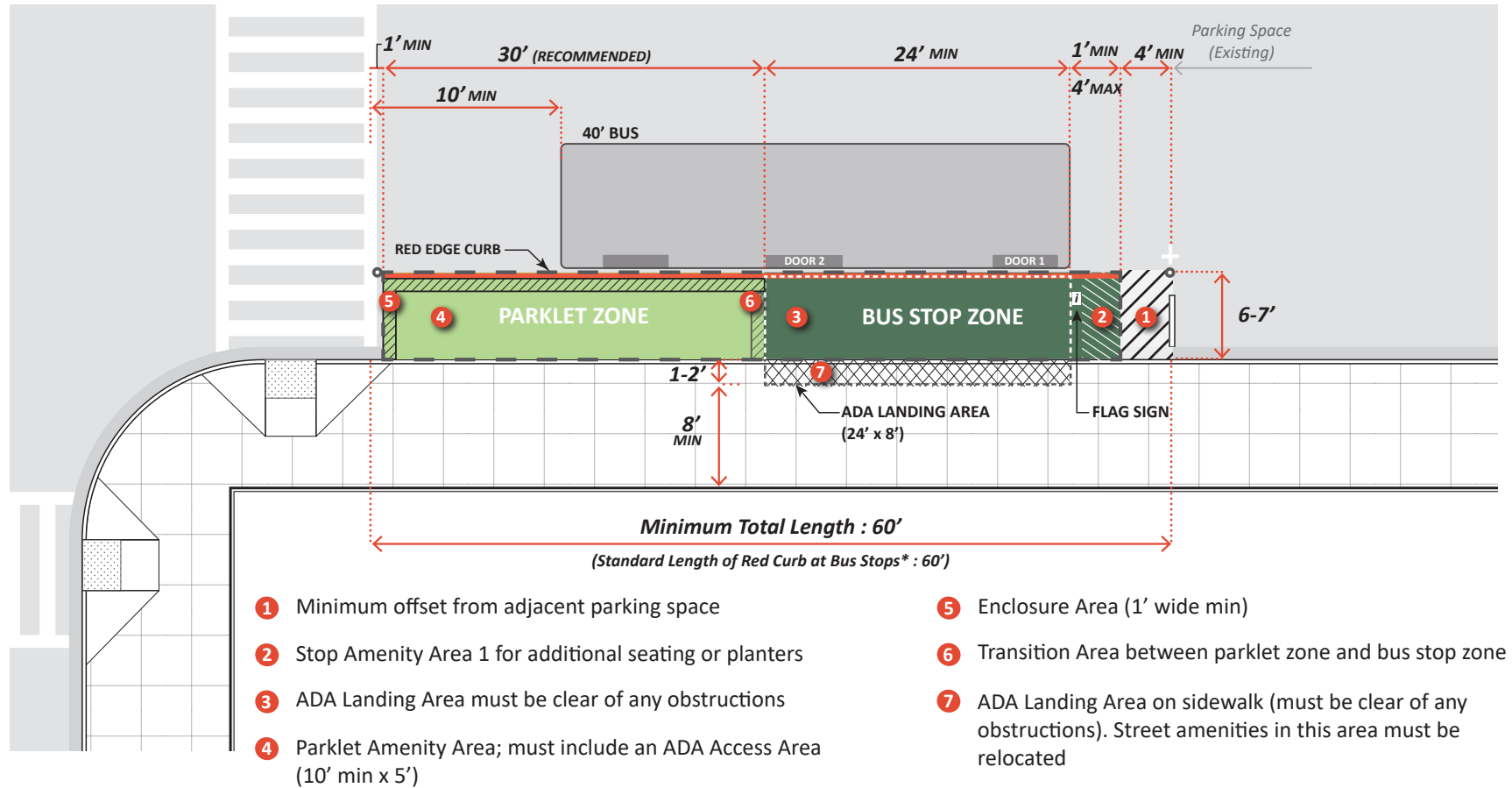

* Developed from guidance per AC Transit's handbook: *Designing with Transit* (2004)

Parallel Parking Configurations with Bulb-Outs and in Mid-Block Locations

1

Summary Table 5.1-5.4 at the end of this chapter provides an overview of recommended dimensions applicable to bus parklets located on streets that have bulb-outs in various locations and bus parklets located at mid-block locations. Specifically, the table reflects the following bus parklets configurations for parallel on-street parking:

2

1. Table 5.1: Located at corner with adjacent bulb-out (Near-side and Far-side).
2. Table 5.2: Located mid-block and with adjacent bulb-out (Near-side and Far-side).
3. Table 5.3: Located mid-block and without adjacent bulb-out (Near-side and Far-side).
4. Table 5.4: Far-side bus parklet with reversed Parklet and Bus Zones¹⁸ (with and without adjacent bulb-out).

3

4

5

6

7

At locations where one end of the bus parklet is located next to an adjacent bulb out (curb extension) the following options for the treatment of the space between bus parklet and adjacent angled curb should be considered:

Option 1: Leave space unused and “as is” and include in daily and weekly clean-up routines.

Option 2: Customize the footprint of the bus parklet structure to fully incorporate the space between curb and parklet into the overall design. Observe all applicable design guidance for bus parklet design elements and the sidewalk-platform interface.

Option 3: Consider filling in the space with a temporary concrete surface, adding the space to the adjacent sidewalk. This approach requires use of a special membrane that is placed between the existing roadway surface and the new concrete in order to allow its easy removal when the parklet is removed in the future. The surface of the new concrete should be flush with the adjacent sidewalk and, if the design of the parklet allows for entering the bus parklet across the new concrete, meet all requirements for the sidewalk-platform interface.



5.2 Prototypical Bus Parklet Layouts and Dimensions for Angled or Perpendicular On-Street Parking

1

The recommended minimum length for a bus parklet is 68 feet for near-side locations and 60 feet for far-side locations. The width of a bus parklet equals the width of the existing angled, or perpendicular parking lane minus one-foot setback from the adjacent travel lane, typically between 12 and 20 feet, depending on the angle of the adjacent angled on-street parking spaces. Unlike bus parklets at locations with parallel parking, a bus parklet installed at angled or perpendicular marking will not require an encroachment of the ADA Loading Area onto the adjacent sidewalk. Another key difference between bus parklets with adjacent parallel parking and bus parklets with adjacent angled parking is the triangular “leftover” space between a rectangular bus parklet and the adjacent parking space. The treatment of this area should be selected from the following options:

2

3

4

5

6

7

Option 1: Leave space unused and “as is” and include in regular clean-up routines.

Option 2: Customize the footprint of the bus parklet structure to incorporate the triangular space into the overall design. Observe all applicable design guidance for bus parklet design elements.

Option 3: Consider using the triangular space for a bicycle parking corral if its size is sufficient for this use.



Pilot Bus Parklet in Albany

Bus Parklet at a Near-side Stop: Plan View

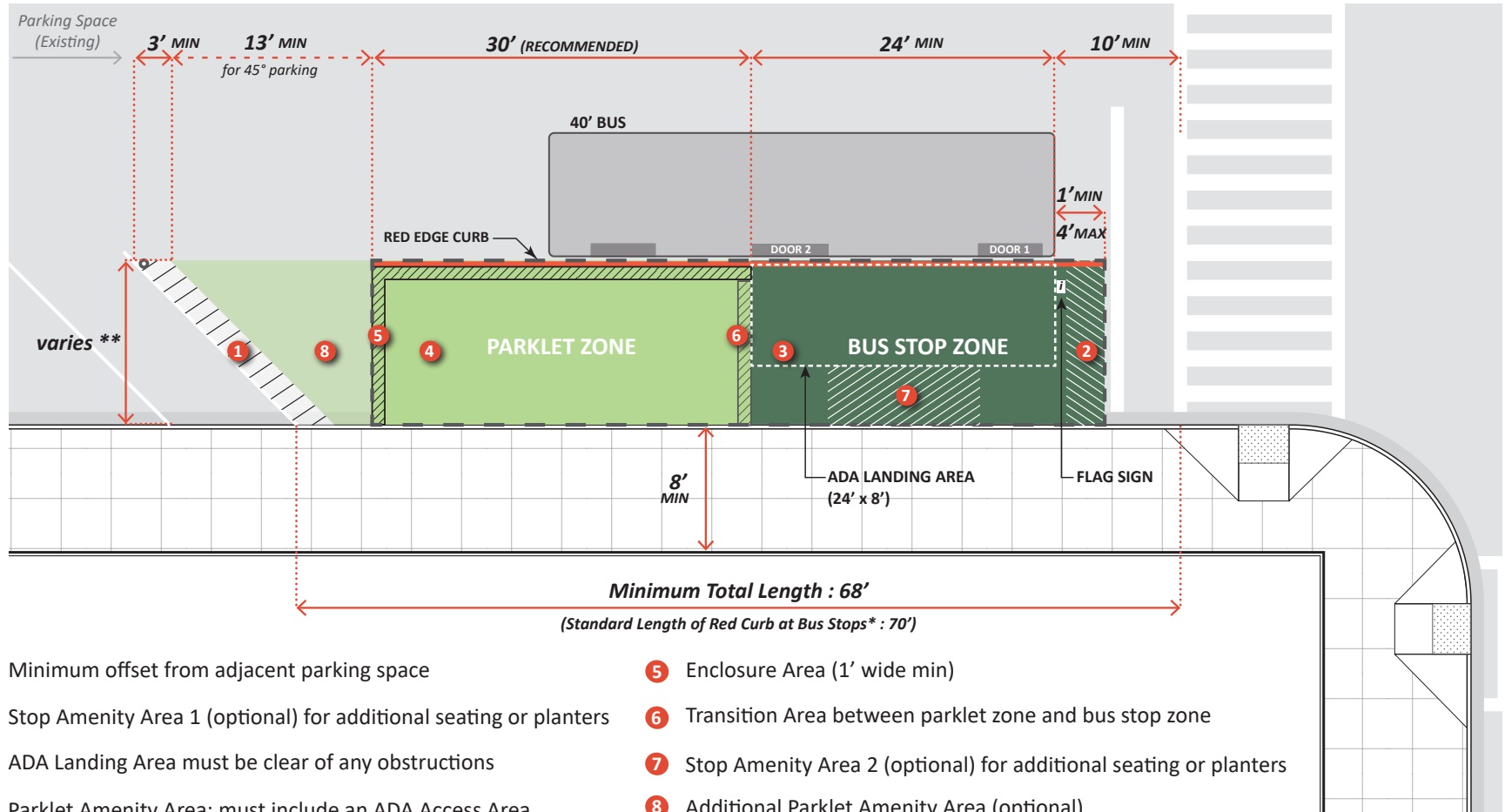

* Developed from guidance per AC Transit's handbook: *Designing with Transit* (2004)

Bus Parklet at a Far-side Stop: 3D View

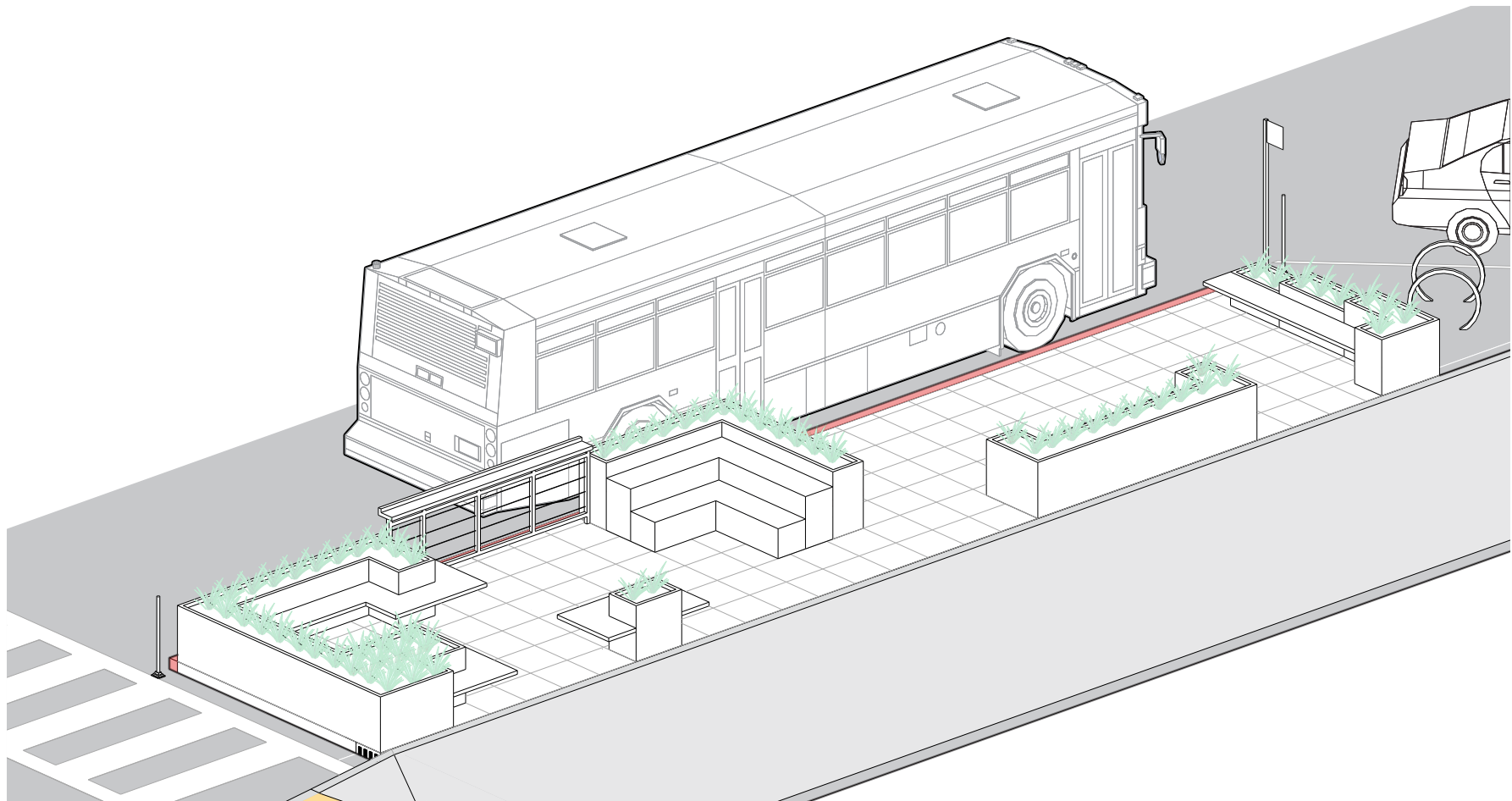

1

2

3

4

5

6

7

Bus Parklet at a Near-side Stop: Plan View

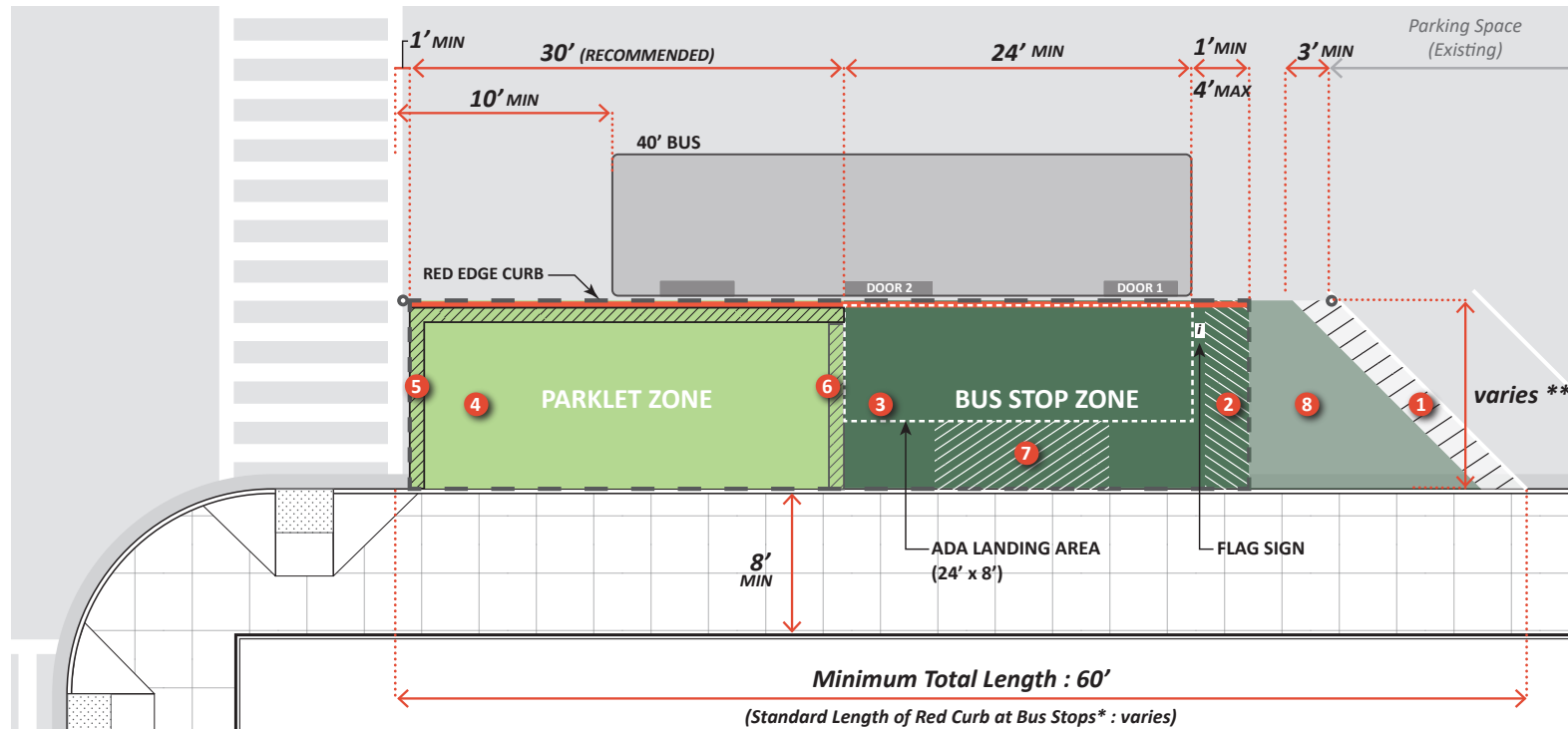

- | | |
|--|---|
| ① Minimum offset from adjacent parking space | ⑤ Enclosure Area (1' wide min) |
| ② Stop Amenity Area 1 (optional) for additional seating or planters | ⑥ Transition Area between parklet zone and bus stop zone |
| ③ ADA Landing Area must be clear of any obstructions | ⑦ Stop Amenity Area 2 (optional) for additional seating or planters |
| ④ Parklet Amenity Area; must include an ADA Access Area (10' min x 5') | ⑧ Additional Bus Stop Amenity Area (optional) |

* The length of the take off zone may vary making the effective length of red curb greater than 60'

Angled or Perpendicular Parking Configurations with Bulb-Outs and in Mid-Block Locations

1

Summary Table 5.1-5.4 at the end of this chapter provides an overview of recommended dimensions applicable to bus parklets located on streets that have bulb-outs in various locations and bus parklets located at mid-block locations. Specifically, the table reflects the following bus parklets configurations for parallel on-street parking:

2

1. Table 5.1: Located at corner with adjacent bulb-out (Near-side and Far-side).
2. Table 5.2: Located mid-block and with adjacent bulb-out (Near-side and Far-side).
3. Table 5.3: Located mid-block and without adjacent bulb-out (Near-side and Far-side).
4. Table 5.4: Far-side bus parklet with reversed Parklet and Bus Zones¹⁹ (with and without adjacent bulb-out).

3

4

5

6

7

At locations where one end of the bus parklet is located next to an adjacent bulb out (curb extension) the following options for the treatment of the space between bus parklet and adjacent angled curb should be considered:

Option 1: Leave space unused and “as is” and include in daily and weekly clean-up routines.

Option 2: Customize the footprint of the bus parklet structure to fully incorporate the space between curb and parklet into the overall design. Observe all applicable design guidance for bus parklet design elements and the sidewalk-platform interface.

Option 3: Consider filling in the space with a temporary concrete surface, adding the space to the adjacent sidewalk. This approach requires use of a special membrane that is placed between the existing roadway surface and the new concrete in order to allow its easy removal when the parklet is removed in the future. The surface of the new concrete should be flush with the adjacent sidewalk and, if the design of the parklet allows for entering the bus parklet across the new concrete, meet all requirements for the sidewalk-platform interface.



- 1
- 2
- 3
- 4
- 5
- 6
- 7

Table 5.1: Located at corner with adjacent bulb-out (Near-side and Far-side)

CORNER WITH ADJACENT BULB-OUT : NEAR-SIDE BUS PARKLET

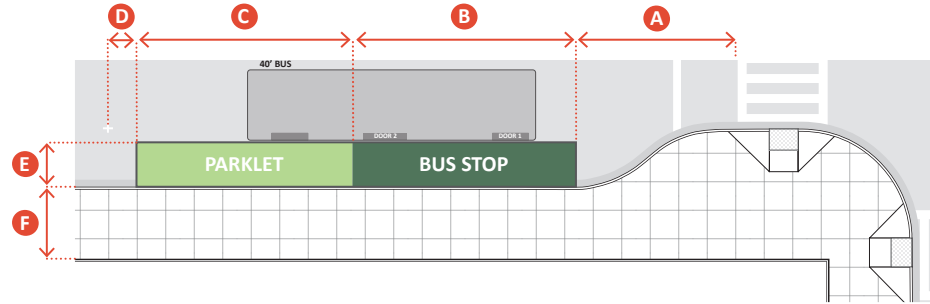

Type of Parking	A	B	C	D	E	F
Parallel Parking	10' **	25'	30'	4'	6' - 7'	10'
Angled/Perpendicular Parking	10' **	25'	30'	3'	varies*	8'

* Width of bus parklet = (Width of existing parking lane - 1) feet
 ** or at the curb return, whichever is farthest

All dimensions are minimums

CORNER WITH ADJACENT BULB-OUT : FAR-SIDE BUS PARKLET

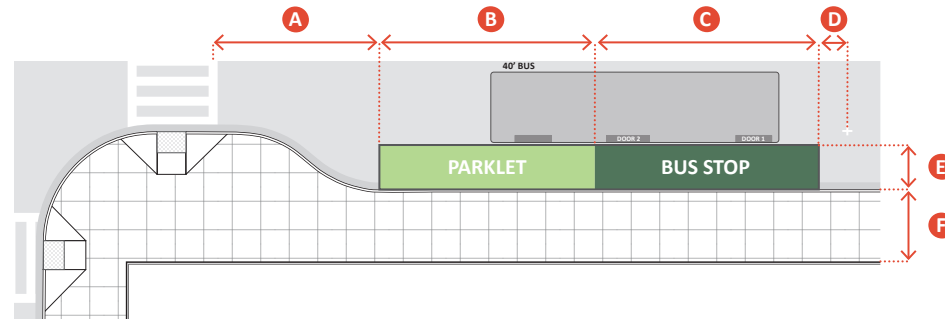

Type of Parking	A	B	C	D	E	F
Parallel Parking	10' **	30'	25'	4'	6' - 7'	10'
Angled/Perpendicular Parking	10' **	30'	25'	3'	varies*	8'

* Width of bus parklet = (Width of existing parking lane - 1) feet
 ** or at the curb return, whichever is farthest

All dimensions are minimums

MID-BLOCK AND WITH ADJACENT BULB-OUT : NEAR-SIDE BUS PARKLET

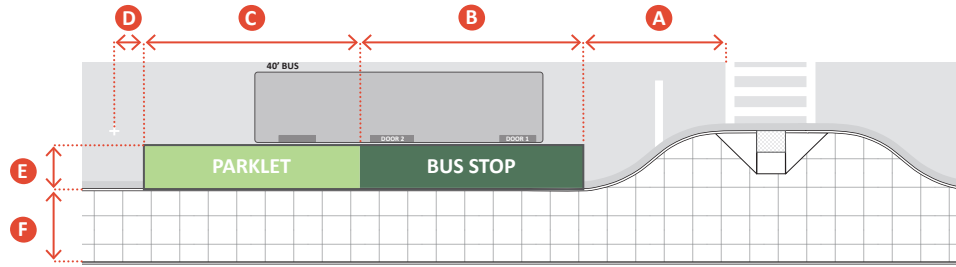

Table 5.2: Located mid-block and with adjacent bulb-out (Near-side and Far-side)

Type of Parking	A	B	C	D	E	F
Parallel Parking	10' **	25'	30'	4'	6' - 7'	10'
Angled/Perpendicular Parking	10' **	25'	30'	3'	varies*	8'

* Width of bus parklet = (Width of existing parking lane - 1) feet
 ** or at the curb return, whichever is farthest

All dimensions are minimums

MID-BLOCK AND WITH ADJACENT BULB-OUT : FAR-SIDE BUS PARKLET

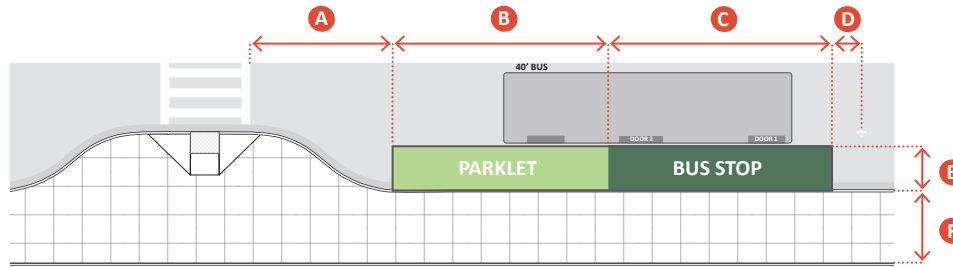

Type of Parking	A	B	C	D	E	F
Parallel Parking	10' **	30'	25'	4'	6' - 7'	10'
Angled/Perpendicular Parking	10' **	30'	25'	3'	varies*	8'

* Width of bus parklet = (Width of existing parking lane - 1) feet
 ** or at the curb return, whichever is farthest

All dimensions are minimums



Table 5.3: Located mid-block and without adjacent bulb-out (Near-side and Far-side)

1
2
3
4
5
6
7

MID-BLOCK AND WITHOUT ADJACENT BULB-OUT : NEAR-SIDE BUS PARKLET

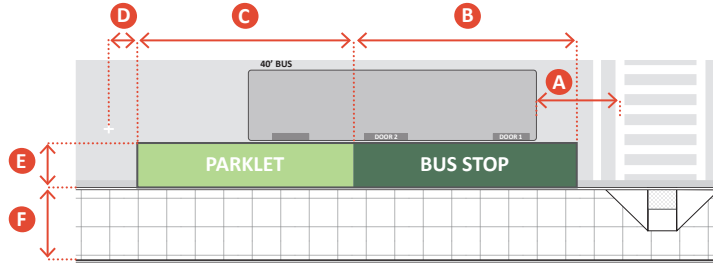

Type of Parking	A	B	C	D	E	F
Parallel Parking	10'	25'	30'	4'	6' - 7'	10'
Angled/Perpendicular Parking	10'	25'	30'	3'	varies*	8'

* Width of bus parklet = (Width of existing parking lane - 1) feet

All dimensions are minimums

MID-BLOCK AND WITHOUT ADJACENT BULB-OUT : FAR-SIDE BUS PARKLET

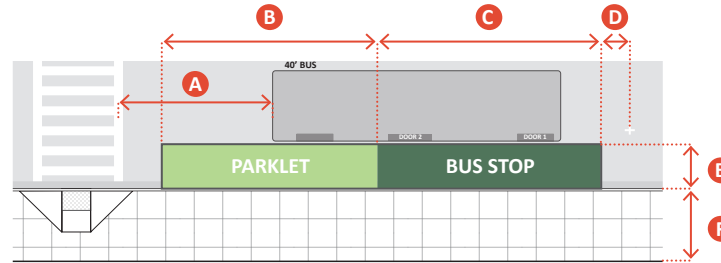

Type of Parking	A	B	C	D	E	F
Parallel Parking	10'	30' **	25'	4'	6' - 7'	10'
Angled/Perpendicular Parking	10'	30' **	25'	3'	varies*	8'

* Width of bus parklet = (Width of existing parking lane - 1) feet

All dimensions are minimums

** Edge of bus parklet must be 1 feet away from the crosswalk

STANDARD PARKLET WITH REVERSED PARKLET AND BUS STOP ZONES

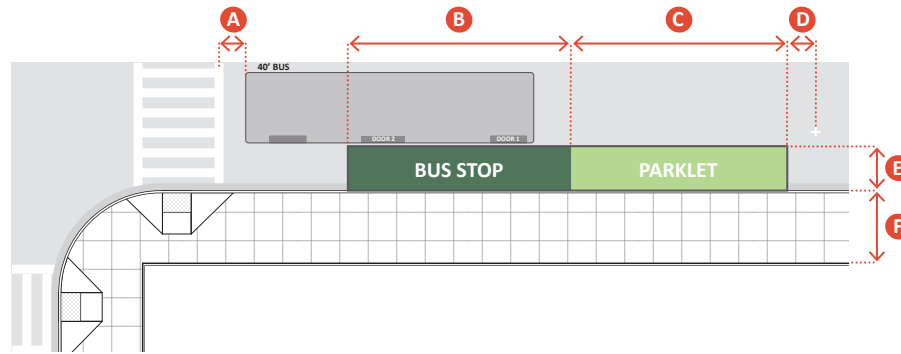

Type of Parking	A	B	C	D	E	F
Parallel Parking	10'	41'	30'	4'	6' - 7'	10'
Angled/Perpendicular Parking	10'	41'	30'	3'	varies*	8'

* Width of bus parklet = (Width of existing parking lane - 1) feet

All dimensions are minimums

Table 5.4: Far-side bus parklet with reversed Parklet and Bus Zones (with and without adjacent bulb-out)

PARKLET AT A CORNER WITH ADJACENT BULB-OUT WITH REVERSED PARKLET AND BUS STOP ZONES

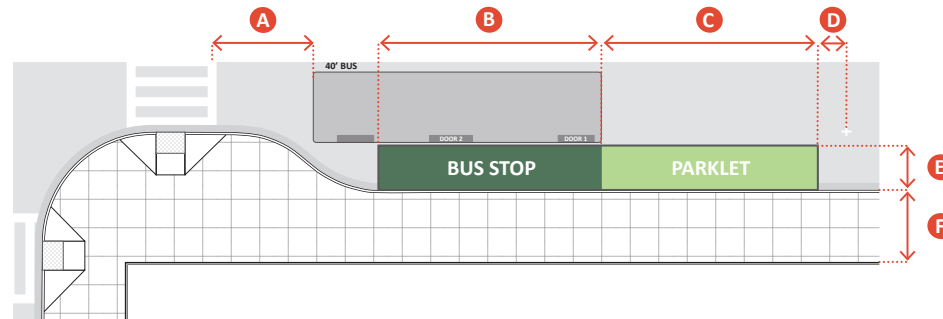

Type of Parking	A	B	C	D	E	F
Parallel Parking	10' **	41'	30'	4'	6' - 7'	10'
Angled/Perpendicular Parking	10' **	41'	30'	3'	varies*	8'

* Width of bus parklet = (Width of existing parking lane - 1) feet

All dimensions are minimums

** or at the curb return, whichever is farthest



1

2

3

4

5

6

7

This page intentionally left blank

6. Bus Parklet Maintenance



The on-going maintenance of bus parklet structure, amenities, and planting as well as regular cleanup of the bus parklet and its surrounding area are essential to its long-term success with respect to functionality, contribution to streetscape aesthetics, and acceptance by bus riders and the local community at large.

The following recommendations are based on input received from AC Transit, the discussion of maintenance in the reviewed best practices documents for bus-bulbs and parklets, as well as information received in interviews conducted for this Bus Parklet Study.

1

Regular maintenance of the bus parklet and both the Parklet and Bus Stop Zones should be the responsibility of the bus parklet sponsor and include:

- Daily pick-up of trash on and around the bus parklet;
- Regular watering of plants as necessary based on the selected drought tolerant plant material (if plants and planters are part of the bus parklet design);
- Weekly sweeping and/or hosing of the area under the platform to remove any debris, sediments, and trash that may interfere with the flow of stormwater runoff. Particular attention should be given to the clearing of the roadway gutter under the platform;
- Regular repair and upkeep of all parts of the bus parklet structure and amenities.
- Removal of graffiti on an as needed basis (also see below).

2

3

4

AC Transit’s maintenance responsibilities will be limited to the following:

- Maintenance and repair of the bus flag sign and pole as well as any schedules, maps, or other displays installed on the pole by AC Transit;

5

6

At its discretion and pending the availability of funding, AC Transit could consider providing the bus parklet sponsor with monetary assistance for maintenance carried out in the Bus Stop Zone of the bus parklet.

7

7. References/Endnotes



Endnotes

- 1 Of the researched parklet programs Portland's is the only program that permits parklets on streets with a posted speed limit above 25 mph (30 mph)
- 2 According to dimensions provided in AC Transit's *Designing with Transit* (2004), it can be inferred that the length of red curb zone for a typical Near-side Bus Stop is 70 feet (standard bus) and for a typical Far-side Bus Stop: 60 feet (standard bus)
- 3 This dimension is based on a standard parklet as described in the *San Francisco Parklet Manual*.
- 4 The overall bus parklet dimensions were derived by taking the standard bus stop length reflected in *Designing with Transit* and subtracting the length of the take-off taper and by including in the overall length a 10-foot clearance between front or rear of the bus to the edge of an adjacent crosswalks as recommended in NACTO's *Transit Street Design Guide*.
- 5 This guidance is based on the dimensions indicated in NACTO's *Transit Street Design Guide*.
- 6 This guidance is based on the dimensions indicated in NACTO's *Transit Street Design Guide*.
- 7 This dimension is based on the guidance contained in AC Transit's *Multimodal Corridor Guidelines*, which includes the placement of floating transit islands at crosswalks in an analogous location to that of a bus parklet.
- 8 This recommendation is based on input received during the interviews with transit agency staffs. The recommendation is intended to address frequently encountered driver behavior at far-side stops with permanent bus-bulbs on two-lane street. There drivers are often seen blocking the far-side crosswalk after taking a right turn or continuing going straight through the intersection only to realize that the car has to be stopped behind a bus at the far-side stop. Providing space that can accommodate one car reduces the potential for the far-side crosswalk to be blocked by a car stopped behind the bus.
- 9 This guidance is based on parklet program guidelines in San Francisco and other jurisdictions.
- 10 This guidance is based on conditions at the constructed Solano Avenue pilot bus parklet and the 12-inch clearance recommended in San Francisco's *Parklet Design Manual*. It should be noted that AC Transit's *Multimodal Corridor Guidelines* document does not indicate a setback for the bus boarding island.
- 11 Based on the assumption that an average driver's eyes are located 3.5 feet above the roadway (per Caltrans Highway Design Manual).
- 12 Based on the assumption that an average driver's eyes are located 3.5 feet above the roadway (per Caltrans Highway Design Manual).
- 13 These summary recommendations are based on guidance provided in the *San Francisco Parklet Manual*.

- 14 The *San Francisco Parklet Manual* specifies the following: “The top surface height of wheelchair accessible tables, counters and or drink rails should be 28 inches to 34 inches above the Deck Surface. Wheelchair accessible tables, counters, and drink rails shall be approachable from the front and provide an unobstructed knee clearance that is at least 27 inches high, 30 inches wide and 19 inches deep... Where drink rails are provided, a 60-inch long portion of a drink rail shall have 36-inch-wide and level space adjacent to it for a side-approach by a wheelchair user.”
- 15 Available at <http://www.stopwaste.org/resource/brochures/bay-friendly-landscape-guidelines-sustainable-practices-landscape-professional>
- 16 The guidance to distinguish the branding of the parklet from the branding of the sponsoring business is based on San Francisco’s requirement to not allow commercial use of the parklet and instead emphasize the design of the parklet as a public space.
- 17 Available at <http://www.stopwaste.org/resource/brochures/bay-friendly-landscape-guidelines-sustainable-practices-landscape-professional>
- 18 This optional reversal of zones may be desirable where a bus parklet sponsor’s business would otherwise be located unreasonably far from the Parklet Zone. Two potential drawbacks of this configuration should be noted: 1) due to applicable recommendations for setbacks, a bus parklet with reversed zones will have a larger overall length and therefore an increased cost; and 2) a more distant location of the Bus Stop Zone from the street corner potentially increases pedestrian travel during transfers and may not be compatible with AC Transit’s expectations for customer access. This configuration should therefore only be used after a case-by-case review of local conditions and bus operations.
- 19 This optional reversal of zones may be desirable where a bus parklet sponsor’s business would otherwise be located unreasonably far from the Parklet Zone. Two potential drawbacks of this configuration should be noted: 1) due to applicable recommendations for setbacks, a bus parklet with reversed zones will have a larger overall length and therefore an increased cost; and 2) a more distant location of the Bus Stop Zone from the street corner potentially increases pedestrian travel during transfers and may not be compatible with AC Transit’s expectations for customer access. This configuration should therefore only be used after a case-by-case review of local conditions and bus operations.

1

2

3

4

5

6

7

This page intentionally left blank

APPENDIX 1: Funding Strategy



A.1.1 Introduction

Strategic Economics was retained by AC Transit, as part of the Community Design + Architecture team, to identify funding strategies for multi-purpose bus parklets. Bus parklets are temporary improvements located in the parking lane that combine transit stop and parklet functions into a single platform design to accommodate both. AC Transit has partnered with the City of Albany to implement a pilot bus parklet on Solano Avenue and would like to help advance this concept as well as understand key considerations for its replication in other locations.

The purpose of this memorandum is to summarize the key findings regarding funding the construction and maintenance of recently constructed bus parklets in the East Bay, as well as identify possible funding sources for future bus parklets.

A.1.2 Case Studies

Strategic Economics conducted interviews with local sponsors of recently constructed parklets in the East Bay. In order to adequately understand the key issues around implementing parklets, the questions were focused on costs and funding sources and maintenance. Parklet sponsors also shared lessons regarding the permitting and construction processes.

Key findings are described below and summarized in **Exhibit A-1.1**.

Costs and Funding Sources

- **The estimated cost of construction for the parklets ranged between \$15,000 to \$100,000, depending on design factors, materials, and participation from volunteers.** Sponsors of the lower cost parklets tended to use inexpensive and/or donated building materials (i.e. typically recycled wood). Their costs were also lower because they relied heavily on volunteers to build the parklets. The parklet sponsor of the highest cost parklet (Parklet #4) solicited a full-service engineering company for design and construction, which relied on higher-quality materials (e.g., steel) and special design features. For example, this parklet incorporated design features to minimize storm-water impacts. It was constructed on an elevated platform ramp with debris screens, which allowed water to flow freely and ease of cleaning.
- **Parklets had various funding sources, including contributions from businesses, property owners, business improvement districts, and private donors.** Sponsors were unable to provide detailed information regarding funding sources by type. However, the majority of the funding for parklet construction was privately raised by businesses or property owners. Two parklets received some financial assistance from the business improvement district. Private donor contributions and donations from crowdsourcing platforms (e.g., Kickstarter) were also an important source of funding. One parklet sponsor solicited ten “business sponsorships” from neighboring businesses, ranging from \$200 to \$500, but this method was mostly used to garner broader community support.
- **None of the parklets in Oakland and Berkeley received city funding.** Neither city contributed funds to the construction of the parklets. However, parklets that wish to incorporate bicycle parking were able to request bike racks from these cities. The bus parklet in Albany did receive financial assistance from the City, which paid for some construction, landscaping materials, and some staff time.

Maintenance

- **All parklets must be privately maintained by the parklet sponsors.** As part of the Berkeley and Oakland parklet program, sponsors were required to sign a Maintenance Agreement, under which sponsors are responsible for the daily cleaning, maintenance, and repair of their parklets. In general, parklet sponsors say that maintenance costs tend to be minimal and can be rolled into normal business expenses. In Albany, the Public Works Department would be responsible for the maintenance of receptacles, bicycle racks, soft hit posts, and graffiti removal.
- **Parklets that are located within a business improvement can help maintain the parklet.** If a parklet is located within a business improvement district (BID), which elects to provide street cleaning for its storefronts, the parklet can benefit from street cleaning.
- **Drainage was identified as a major challenge.** All parklet sponsors identified curbside drainage as the primary challenge in terms of maintenance. During heavy rains, parklets can block storm-water flow. The area around and under parklet platforms must be swept clean on a regular basis.
- **Parklet sponsors said the use of durable materials and low-maintenance landscaping are strongly encouraged.** Durable materials can withstand weather events and constant public use, yet flexible and light enough to be easily disassembled if required. Low-maintenance landscaping and drought tolerant plants can provide aesthetic elements to the overall streetscape, but it is important that they do not block pedestrian or vehicular movement or visibility.

Permitting and Construction

- **Four of the parklets were established as part of their cities' pilot parklet programs.** Both the cities of Oakland and Berkeley have enacted parklet programs out of a desire to create more pedestrian-friendly activity on city streets. As a step towards designing a permanent program, both cities limited the length of their pilot programs, the locations, and the number of parklets allowed. The piloted parklets were selected based on a set of criteria, such as how it would enhance the aesthetic quality of the streetscape and show evidence that the parklet will be well-maintained. The parklet sponsor must also demonstrate community support for public space at the location.
- **Oakland and Berkeley's parklet programs established procedures and conditions for approval of parklets, as well as permit fees.** In the cities of Oakland and Berkeley, parklet sponsors must first obtain a Minor Encroachment Permit to perform work within the cities' public right-of-way. The programs also required sponsors to meet certain conditions, such as follow design parameters, carry insurance, sign a maintenance agreement, and install signage that clearly indicate that the parklet is a public space. The City of Berkeley may also request a performance bond to cover the cost and effort of parklet removal if the parklet must be removed. The application process also included a number of fees, totaling approximately \$1,300 in Oakland and \$1,700 in Berkeley. The City of Oakland also requires an annual renewal fee.
- **Most of the parklets were permitted, designed, and constructed within two years.** Many of the parklet sponsors stated that they devoted a substantial amount of time to project coordination, which took a team effort among designers, artists, planners, and others. A few of the sponsors contended that the permit process was cumbersome and required too many documents, including liability forms. In terms of construction, the actual construction time varied among parklets, depending if parklet construction made use of volunteers or professional contractors. Many of the parklets studied were constructed by volunteers. Sponsors utilized online social media platforms (e.g., Next Door, Facebook), print newsletters and flyers, and word-of-mouth to solicit volunteers. Some sponsors organized festive volunteer day "parties" to encourage community building.

Other Takeaways

Other takeaways and lessons learned from parklet sponsors with regards to implementation are shared below.

- **Parklets impact areas beyond the site where they are located.** Therefore, it is important to solicit support from surrounding neighbors, property owners, and businesses. Construction impacts may also arise, so it is important maintain regular communication with them. One parklet sponsor shared that early community engagement was key to ensure greater "buy in" during implementation.
- **Programming the space with activities and events have helped parklets create community interactions and greater sense of pride.** For example, some of these parklets are now used as Bike to Work Day stations. A parklet in Oakland is designed as a trolley car to honor the neighborhood's transportation history. Sponsors believe these improvements instill a "sense of pride" and deter vandalism.
- **Parklets that offer adjoining bicycle parking can draw more visitors than a parking space for a single car.** Parklets with adjacent bicycle parking can potentially attract more visitors since multiple bike racks can be installed within one conventional parking spot. Adjoining bicycle parking can also create additional buffer and safety between the parklet and cars.
- **The long-term sustainability of parklets are not currently adequately addressed.** Berkeley and Oakland's policies currently require that parklets be removed or transferred to another sponsor in the event of a change in sponsorship. A "plan B" should be considered if for some reason the parklet sponsor can no longer maintain the parklet. For example, it may be incumbent upon the City or other group (i.e., property/business improvement district, or landscaping and lighting district) to "adopt" the parklet if they deem the parklet a valuable asset to keep and maintain.

EXHIBIT A-1.1. Funding Sources: Select Parklets in the East Bay								
Parklet	Parklet Sponsor	Estimated Time of Planning and Construction	Estimated Cost	Cost included	Funding Sources: Capital Construction			
					Parklet Sponsor	Public Agency (City, AC Transit)	Business Improvement District	Donations*
Oakland								
Parklet 1	Business Owner	2 years	\$15,000	Materials only	X			X
Parklet 2	Business Owner	1 to 1.5 years	\$18,000	Some materials, some design services	X		X	X
Berkeley								
Parklet 3	Business Improvement District	1 to 1.5 years	\$60,000	Design services, some materials, and some labor	X		X	X
Parklet 4	Property Owner	1 year	\$100,000	Full construction, including design services, materials, and labor	X			
Albany								
Parklet 5	Business Owner	2 years	\$85,000**	Materials and some labor	X	X		X

*Includes volunteer labor and/or materials

**Estimate provided by City of Albany staff.

Sources: Parklet sponsors.

A.1.3 Funding Sources

Based on the research from the case studies, as well as a review of common sources for similar infrastructure projects, Strategic Economics has identified funding sources for capital construction and maintenance of bus parklets. The funding sources include district-based mechanisms, city funds, regional sources, and private sources. Major categories of funding are described below and summarized in **Exhibit A-1.2**.

BID, PBID, or Landscape and Lighting Districts

Common district-based funding mechanisms include property-based or business improvement districts (also known as PBID or BID), or landscape and lighting districts. These types of districts can collect fees or special assessments in order to fund and maintain certain improvements within the district's boundaries, such as streetscape materials, landscaping, parks, and lighting. These types of funding mechanisms are helpful in providing money for capital construction as well as ongoing maintenance. BIDs were identified as funding sources for two of the case study parklets.

City Funds

If a city has an adopted Complete Streets Plan, Bicycle Master Plan, or Pedestrian Master Plan, there may be city funds available through its Capital Improvement Program (CIP) to fund transportation and streetscape improvements, such as bus parklets. Cities may also apply for competitive funds through the State Department of Transportation's Active Transportation Program (ATP).

AC Transit

AC Transit staff stated that the agency would be responsible for items pertaining to its usual bus operations (i.e., signage poles, maps, and schedules). AC Transit is not a granting agency, therefore any funding for parklet implementation from AC Transit would be made through partnerships between a granting agency and/or cities.

Regional Grants

There are two major regional sources that may provide grant funding for the construction of bus parklets: the One Bay Area Grant (OBAG) program and Alameda County's Measure BB funding. OBAG is a funding and policy framework for the allocation of federal dollars to counties and various agencies across the San Francisco Bay Area.

Adopted in 2014, OBAG 2 is the second round of OBAG and will fund projects from FY 2017-2018 to FY 2021-2022. It has two components: a Regional Program, which funds a variety of regional level projects; and a County Program. Under the OBAG 2 County Program, Congestion Management Agencies (CMAs) are allocated discretionary funding that can be used for transit improvements.¹

Passed by Alameda County voters in 2014, Measure BB funds are distributed to cities and transit agencies to fund transportation improvements, including streetscape projects, as identified in the 2014 Expenditure Plan.² Both grant programs are competitive.

¹ MTC (2015, revised 2017). Resolution No. 4204 OBAG 2. http://mtc.ca.gov/sites/default/files/RES-4202_approved.pdf

² Alameda County Transportation Commission. <https://www.alamedactc.org/2014plan>

Private Sources

A number of private sources can provide funding for construction as well as ongoing maintenance of bus parklets. Interviews with recently-constructed parklet sponsors in Oakland and Berkeley reveal that most parklets were funded and maintained either by the property owner or business owner. Many business owners and property owners also received financial assistance and donations (labor and/or materials) from neighborhood groups or individuals, sometimes through web-based crowdfunding platforms.

EXHIBIT A-1.2: Possible Funding Sources for the Construction and Maintenance of Bus parklets			
	Funding Sources	Capital Construction	Maintenance
District-Based Mechanisms	Property-Based or Business Improvement District	X	X
	Landscape and Lighting District	X	X
City Funds	Capital Improvement Program	X	
AC Transit	AC Transit*	X	
Regional Grants	OBAG (ACTC, MTC)	X	
	ACTC Measure BB	X	
Private Sources	Property owner or developer	X	X
	Local business(es)	X	X
	Group or individual donations (labor and/or materials)	X	X

*AC Transit is not a funding agency. However, on a case-by-case basis and pending the availability of programmed funds, AC Transit may consider providing financial support to the implementation of a bus parklet.

Sources: AC Transit; Strategic Economics, 2018.

APPENDIX 2: Parking Loss Calculator



A.2.1 Parallel Parking

When replacing parallel on-street parking, most bus parklets would require an estimated elimination of three parking spaces. This number may increase if the first parking space is located less than eight feet away from the crosswalk for near-side locations or may decrease if the first parking space is located more than 28 feet away from the crosswalk for near-side locations (20 feet in the case of far-side locations). The total number is also contingent on the length of the parklet. The different scenarios associated with the estimated removal of parking spaces and the corresponding maximum effective lengths of the bus parklet are illustrated in Exhibits A-2.1 and A-2.2.

A.2.2 Angled or Perpendicular Parking

When replacing angled on-street parking, the estimated loss of parking spaces varies based on the angle at which the parking is striped. It ranges from a minimum of seven spaces (for 45-degree layout) to a minimum of nine spaces (for 90-degree layout). This number may increase or decrease depending on the location of first parking space from the existing crosswalk. The total number of removal of parking spaces is also contingent on the length of the parklet.

EXHIBIT A-2.1: Near-side location			
Scenario	Distance (x feet) of First Parking Space from the Crosswalk	Estimated Loss of Parking Spaces ^o	Effective Length of Bus parklet
1	$x < 8$ feet	4 spaces	Bus Stop function: 25 feet (min.) Parklet function: 30 feet (min.) Setbacks: 9 feet (max.) + 4 feet (min.) Extra space*: (12 + x) feet (max.) Total Length: 68 + (12 + x) feet (max.)
2	$x = 8$ feet	3 spaces	Bus Stop function: 25 feet (min.) Parklet function: 30 feet (min.) Setbacks: 9 feet (max.) + 4 feet (min.) Total Length: 68 feet (max.)
3	$x > 8$ feet and $x < 28$ feet	3 spaces	Bus Stop function: 25 feet (min.) Parklet function: 30 feet (min.) Setbacks: 9 feet (max.) + 4 feet (min.) Extra space*: (x - 8) feet (max.) Total Length: 68 + (x - 8) feet (max.)
4	$x = 28$ feet	2 spaces	Bus Stop function: 25 feet (min.) Parklet function: 30 feet (min.) Setbacks: 9 feet (max.) + 4 feet (min.) Total Length: 68 feet (max.)
5	$x > 28$ feet and $x < 48$ feet	2 spaces	Bus Stop function: 25 feet (min.) Parklet function: 30 feet (min.) Setbacks: 9 feet (max.) + 4 feet (min.) Extra space*: (x - 28) feet (max.) Total Length: 68 + (x - 28) feet (max.)
6	$x = 48$ feet	1 space	Bus Stop function: 25 feet (min.) Parklet function: 30 feet (min.) Setbacks: 9 feet (max.) + 4 feet (min.) Total Length: 68 feet (max.)

* The extra space may be minimized by restriping the parking lane. It could alternatively be redistributed to the Bus Stop Zone, Parklet Zone or Buffer Zone.

^o Based on the assumption that the parking striping does not change along the length of the block. The total loss of parking space may be minimized if the parking spaces are re-striped along the block accommodating the bus parklet.

EXHIBIT A-2.2: Far-side location			
Scenario	Distance (x feet) of First Parking Space from the Crosswalk	Estimated Loss of Parking Spaces ^o	Effective Length of Bus parklet
1	$x < 20$ feet	3 spaces	Bus Stop function: 25 feet (min.) Parklet function: 30 feet (min.) Setbacks: 1 feet + 4 feet (min.) Extra space*: x feet (max.) Total Length: 60 + (x) feet (max.)
2	$x = 20$ feet	2 spaces	Bus Stop function: 25 feet (min.) Parklet function: 30 feet (min.) Setbacks: 1 feet + 4 feet (min.) Total Length: 60 feet (max.)
3	$x > 20$ feet and $x < 40$ feet	2 spaces	Bus Stop function: 25 feet (min.) Parklet function: 30 feet (min.) Setbacks: 1 feet + 4 feet (min.) Extra space*: (x - 20) feet (max.) Total Length: 60 + (x - 20) feet (max.)
4	$x = 40$ feet	1 space	Bus Stop function: 25 feet (min.) Parklet function: 30 feet (min.) Setbacks: 1 feet + 4 feet (min.) Total Length: 60 feet (max.)
5	$x > 40$ feet and $x < 60$ feet	1 space	Bus Stop function: 25 feet (min.) Parklet function: 30 feet (min.) Setbacks: 1 feet + 4 feet (min.) Extra space*: (x - 40) feet (max.) Total Length: 60 + (x - 40) feet (max.)

* The extra space may be minimized by restriping the parking lane. It could alternatively be redistributed to the Bus Stop Zone, Parklet Zone or Buffer Zone.

^o Based on the assumption that the parking striping does not change along the length of the block. The total loss of parking space may be minimized if the parking spaces are re-striping along the block accommodating the bus parklet.

APPENDIX 3: Albany Bus Parklet Drawings

Following are the drawings that were prepared for the installation of the Solano Avenue Pilot Bus Parklet. They are provided here for informational purposes only and are not intended for reuse in a different location nor to serve as a template for the preparation of future bus parklet construction drawings (also see Section 1.4 Parklet Design and Application Process).



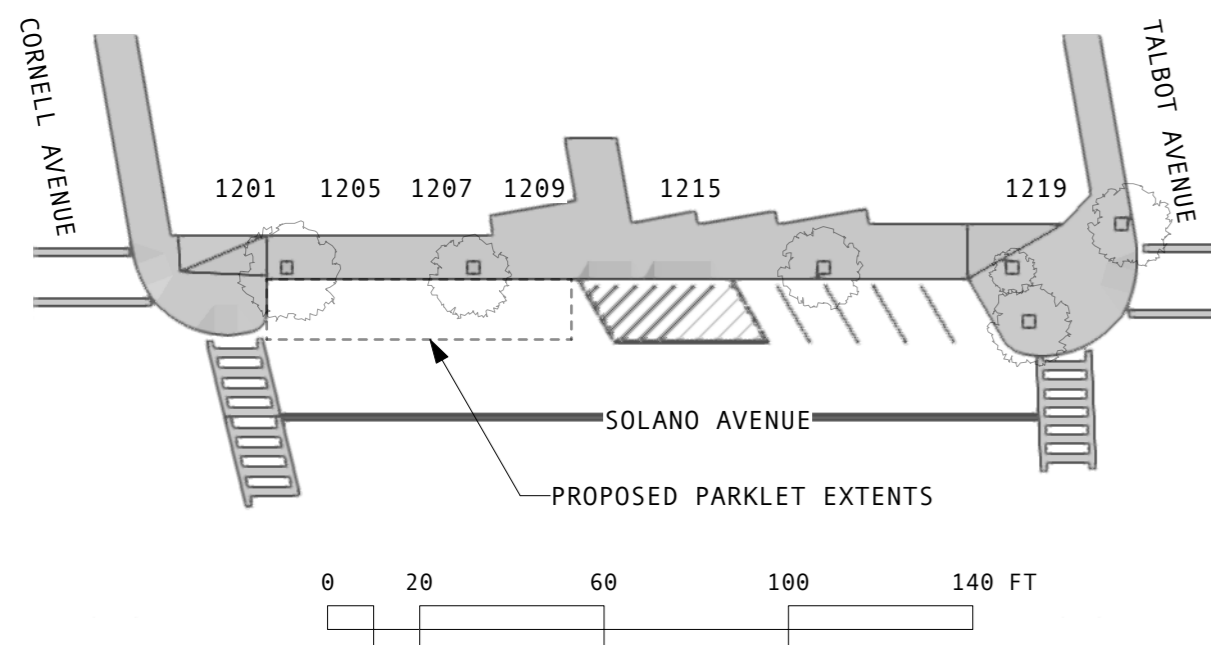

NORTH SIDE 1200 BLOCK SOLANO AVENUE

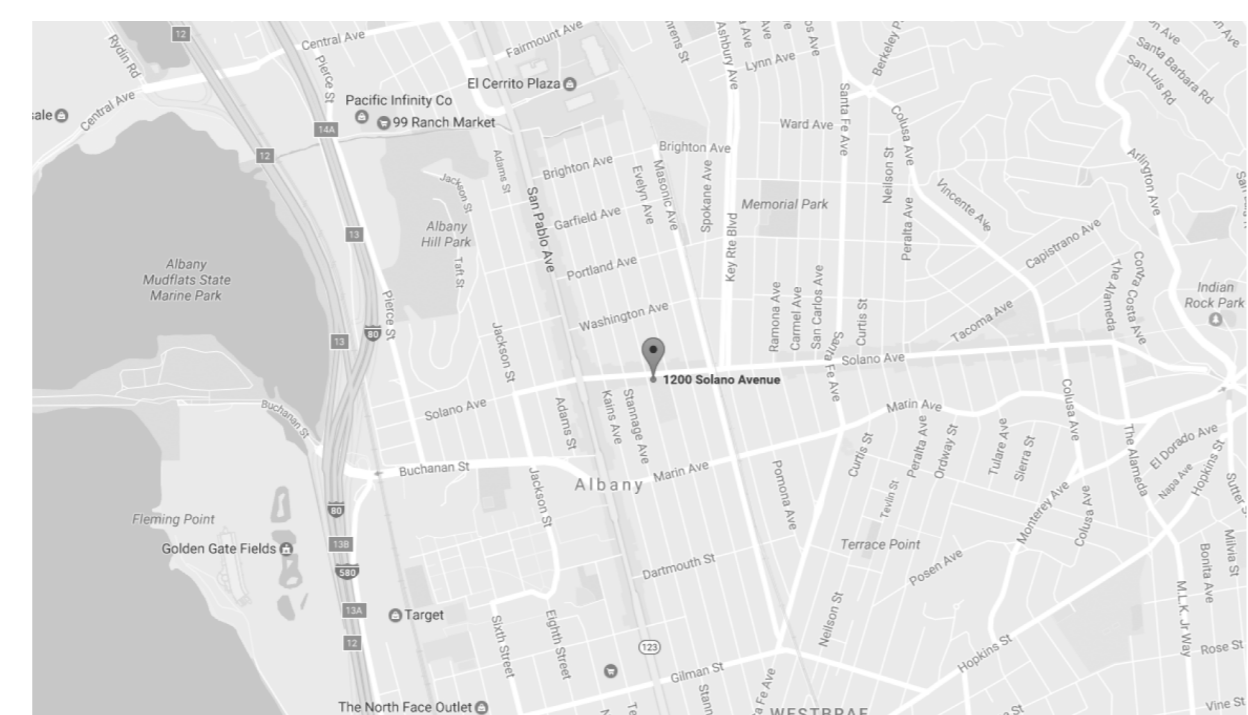

VICINITY MAP

"AS YOU WISH" PARKLET

1200 SOLANO AVENUE, ALBANY, CALIFORNIA

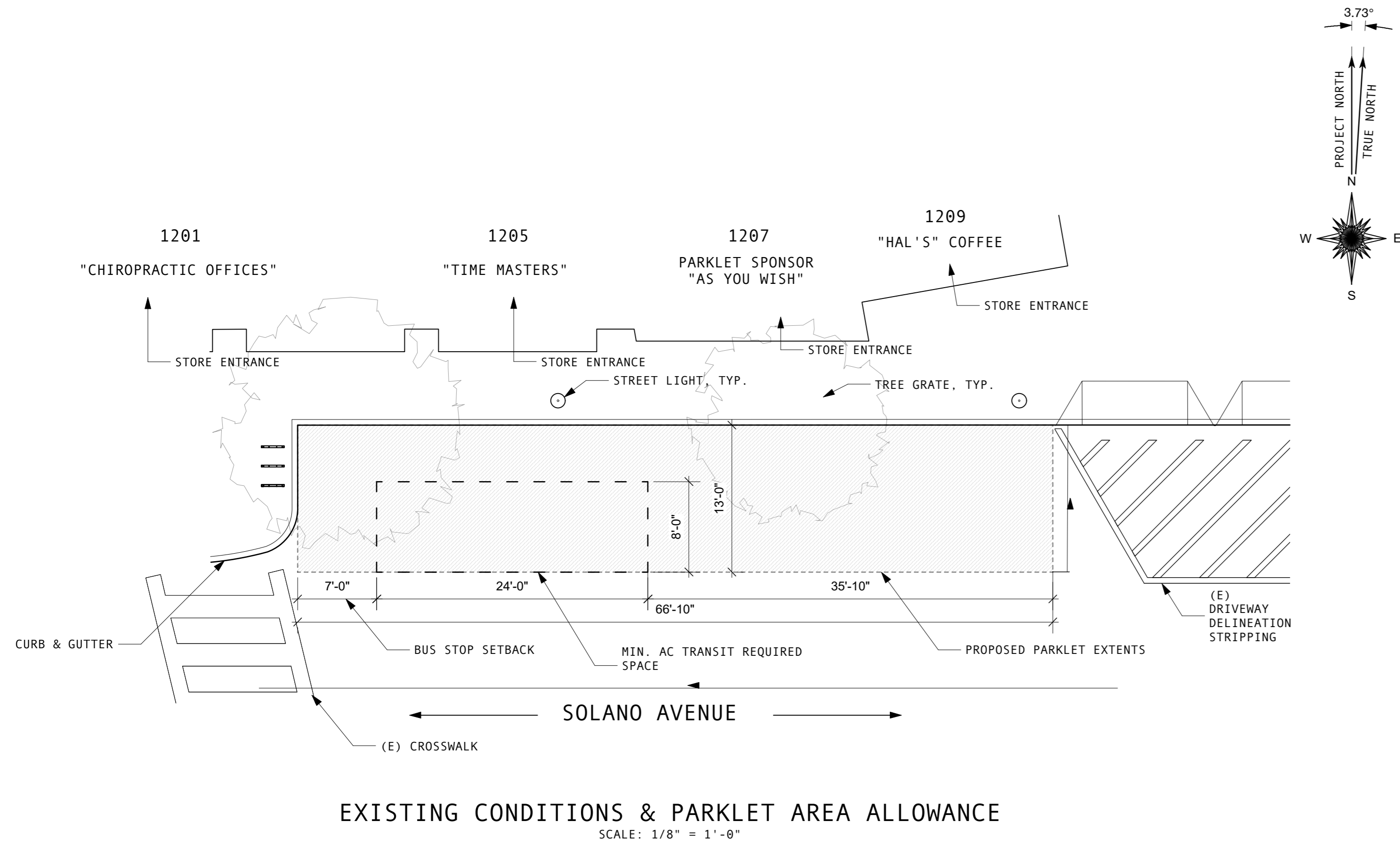
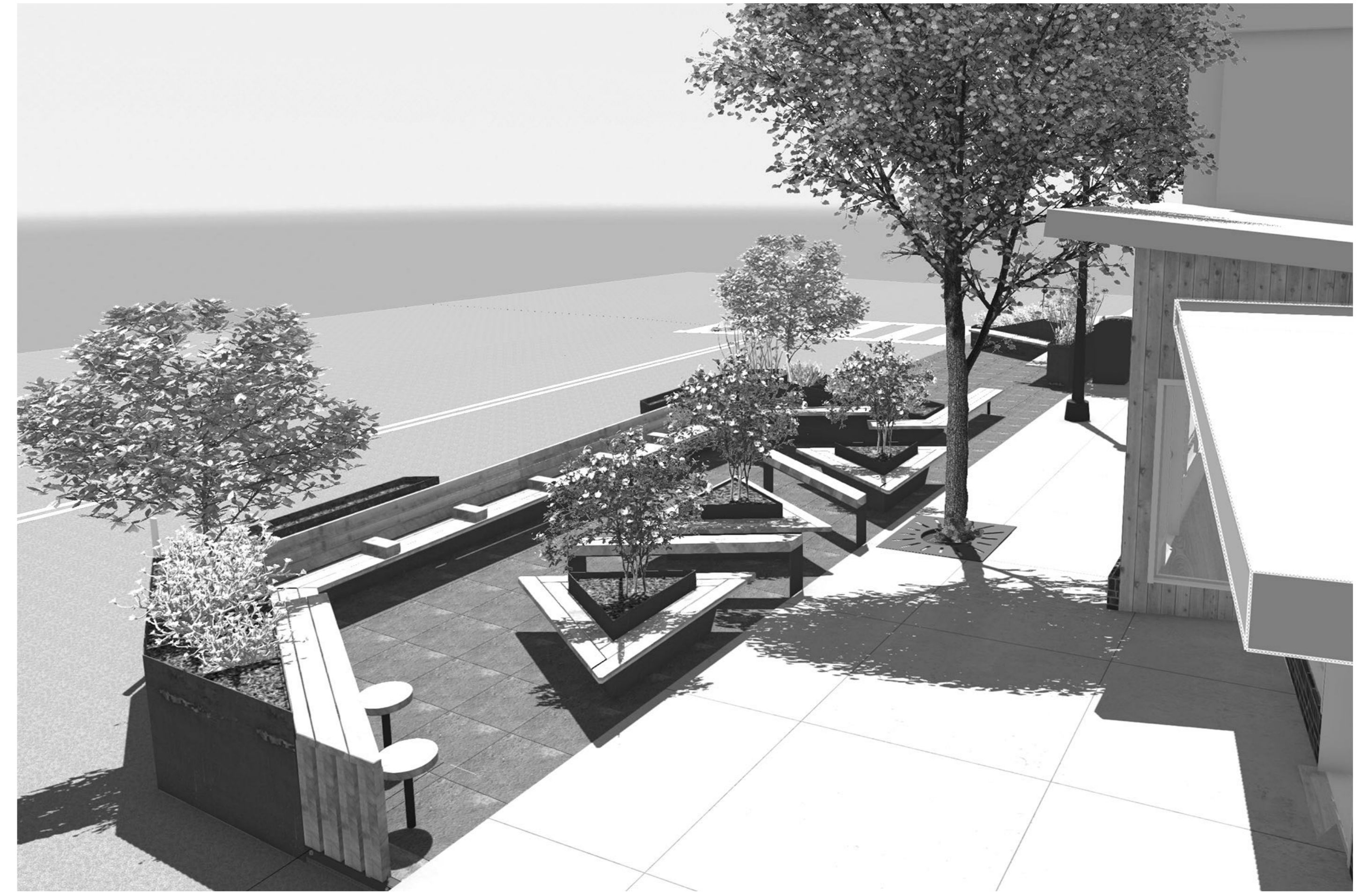

EXISTING CONDITIONS & PARKLET AREA ALLOWANCE
SCALE: 1/8" = 1'-0"

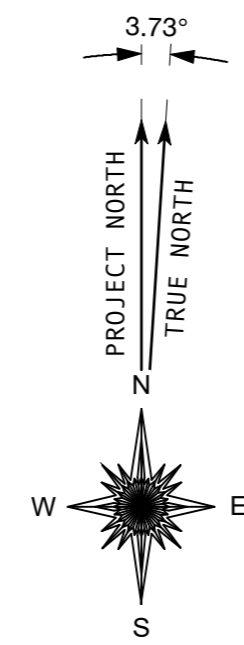

CONTACT INFO

SPONSORS/DESIGNERS
ABRAHAM & BONNIE ELTERMAN
 1205 Solano Ave
 Albany, CA 94706
 510.593.3466
 bonnee.elterman@gmail.com
 elterman.abraham@gmail.com

DRAWINGS & ARCHITECTURAL DESIGN
STEPHEN HEINEN
 644 Ocean Ave., Richmond, CA 94801
 307.921.0880
 stephenheinen@gmail.com

CHELLE PUTZER
 CITY OF ALBANY PARKS & RECREATION COMMISSION
 1249 Marin Avenue
 Albany, CA 94706

STEPHEN NEWHOUSE
 TRANSPORTATION PLANNER, AC TRANSIT
 1600 Franklin Street, Oakland, CA 94612
 Office 501.891.4867, Cell 510.502.6518

ALEIDA ANDRINO-CHAVEZ, AICP
 TRANSPORTATION PLANNER, CITY OF ALBANY
 1800 San Pablo Ave., Albany, CA 94706
 510.528.5759
 achavez@albanycal.org

Rbhu Engineering
 Engineering Imagination
 415.967.2525
 Selinda Martinez P.E.

SITE INFORMATION

LOCATION: 1200 SOLANO AVE., ALBANY, CA 94701
 ZONING: "SC" SOLANO COMMERCIAL

PARKLET EXTENTS: 869 SQFT.
 PERIPHERAL AREAS INCLUDE INSTALLATION OF SIDEWALK BIKE RACKS, STREET DELINEATORS AND SIGNAGE.

SCOPE OF WORK

1. FABRICATION AND INSTALLATION OF STEEL PLATE PLANTER BOX PANELS. ON-SITE WELDED ASSEMBLY. INSTALLATION OF STEEL PERIMETER EDGING AND LEDGERS; REMOVEABLE GUTTER GRATING.
2. INSTALLATION OF BENCH, BAR & STOOL SUPPORTS.
3. PLACEMENT OF PEDISTAL DECK SUPPORTS.
4. PLACEMENT OF DECK PAVERS.
5. FABRICATION, INSTALLATION AND FINISHING OF WOOD BENCHES, TABLES AND BARS.
6. BIKE RACK INSTALLATION.
7. BIG BELLY TRASH RECEPTACLES INSTALLATION. (N/A)
8. SIGNAGE INSTALLATION.
9. INSTALLATION OF FLEX HIGH VISIBILITY REFLECTIVE TRAFFIC DELINEATORS (STREET CENTER DIVIDER); BOLLARDS (HEAD OF PARKLET FACING ONCOMING TRAFFIC).
10. PLANTER WATERPROOFING.
11. PLACEMENT OF DRAINAGE AND SOIL MATERIALS.
12. INSTALL TREES AND PLANTS.

PROJECT DESCRIPTION

PROPOSED DEVELOPMENT OF A LONG STANDING AC TRANSIT BUS ZONE ON THE NORTH SIDE 1200 BLOCK, SOLANO AVE. THE 13' X 67' AREA PROVIDES ROOM FOR A CURBSIDE PARKLET AND BUS STOP COMBO.

THE ARRANGEMENT OF SEATING AND PLANTING AREAS, FEATURING UNIQUE TRIANGULAR RELATIONSHIPS, CREATE A FLOWING AND INCLUSIVE HANG OUT FOR EATING AND SOCIALIZING. SEATING AND PLANTER HEIGHTS FOLLOW A RELATIVE RELATIONSHIP WITH THE GENTLY SLOPING STREET.

THE TRANSIT DOCK AREA PROVIDES AMPLE LENGTH FOR LOADING AND UNLOADING PASSENGERS FROM BOTH ENDS OF THE BUS.

PLANTER BOXES USE STEEL PLATE TO MINIMIZE MASS AND CREATE CLEAN AND CRISP ARCHITECTURAL FORMS DEFINING THE SEATING AND GROUPING AREAS. FRIENDLY CEDAR WOOD PROVIDES A NEUTRAL INTERFACE BETWEEN THE STEEL WHILE PLANTING AND TREES FEATHER THE AIR. BIKE RACKS AND RECYCLING/TRASH RECEPTACLES ARE PROVIDED FOR USER CONVENIENCE.

CONCRETE PAVERS OVER A PEDESTAL SYSTEM PROVIDE A SEMIPERMEABLE SURFACE AND EASY ACCESS BELOW THE DECK WHERE WATER RUNOFF FLOWS THROUGH AND AROUND PLANTER BOX BASE AGGREGATE AND UNIMPEDED DOWN THE GUTTER CHANNEL.

TABLE OF CONTENTS

- A0.1 COVER & INFO: (E) SITE & (P) PROJECT ISOMETRIC
- A1.1 PLAN
- A2.1 ELEVATIONS; SECTIONS; DETAILS

Sponsor/Designers: Abraham & Bonnie Elterman
 1205 Solano Ave., Albany, CA 94701
 bonnee.elterman@gmail.com

DRAWN BY: STEPHEN HEINEN
 SINGING HAMMERS LLC
 BOX 7 THERIOPOLIS WY. 82443 307.921.0880
 stephenheinen@gmail.com

ISSUE

8/30/16 Concept
 9/16/16 Scheme Selection
 9/29/16 Commissioner Present.
 1/18/17 '658' Review
 1/27/17 Traffic & Safety.
 3/18/17 City Council

"AS YOU WISH" PARKLET
 1205 SOLANO AVE. ALBANY, CA 94706

TITLE
 INFO
 EXISTING SITE
 PROJECT PERSPECTIVE

A 0.1

1201

1205

1207

"CHIROPRACTIC OFFICES"

"TIME MASTERS"

PARKLET SPONSOR
"AS YOU WISH"

"HAL'S OFFICE COFFEE"

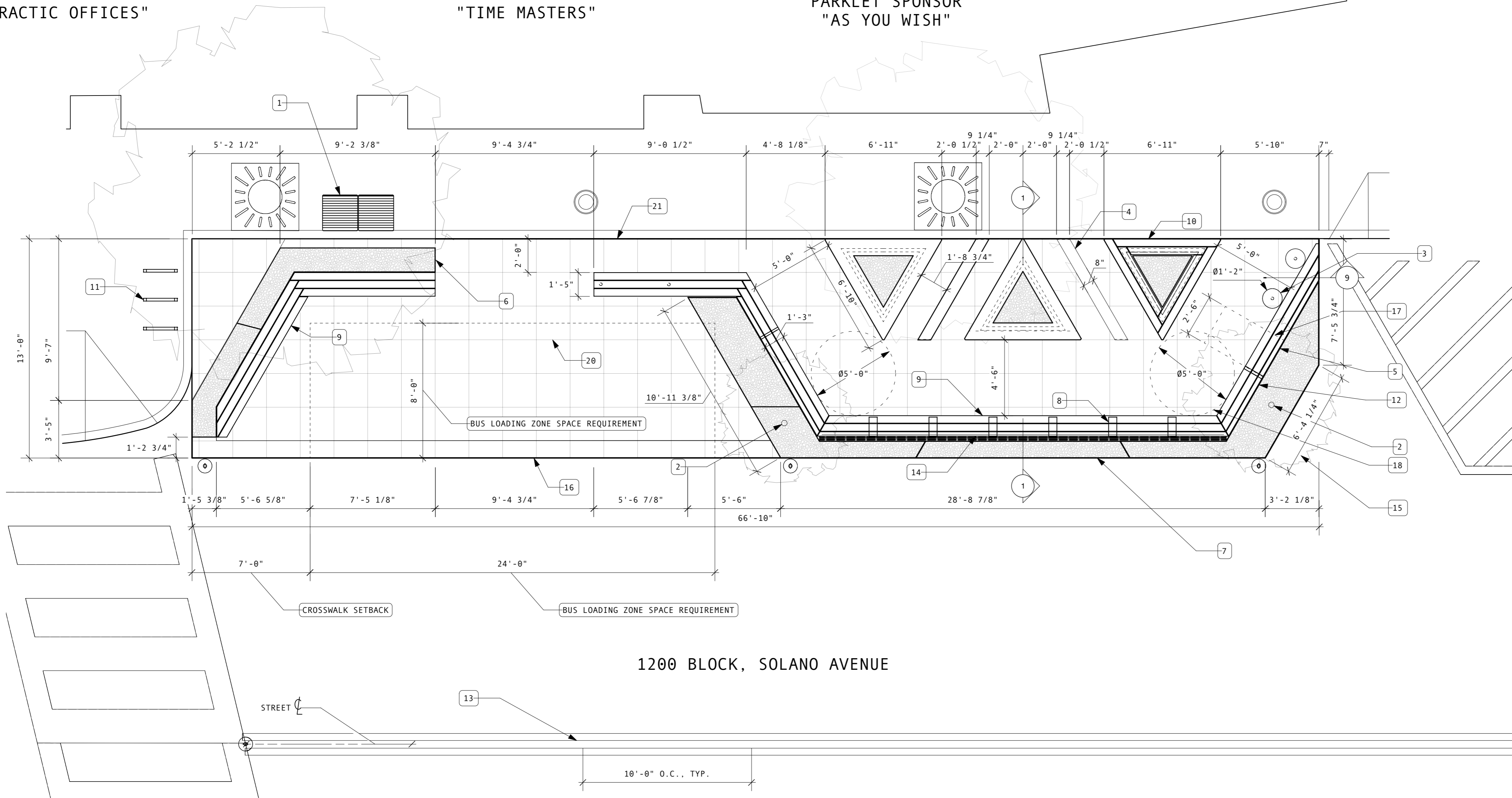

PARKLET PLAN
SCALE: 1/4" = 1'-0"

GENERAL NOTES
MATERIALS & SPECIFICATIONS

- SECTION
- 01 56 23 TEMPORARY BARRICADES
PROVIDE WORKSITE PERIMETER SAFETY & SECURITY FENCING DURING CONSTRUCTION.
 - 01 58 00 PROJECT IDENTIFICATION (BY OTHERS)
 - 05 05 13 SHOP-APPLIED COATINGS FOR METAL
HEAT APPLIED WAX FINISH.
 - 05 05 23 METAL FASTENINGS
MISC. DROP & EXPANSION ANCHORS.
 - 05 50 01 METAL FABRICATIONS
1) 3/16" STEEL PLATE PLANTER BOX WALLS.
2) 3/16" STEEL PLATE TRANSIT DECK CURB FACING & ANCHORING BRACKETS.
3) 18 GAUGE STEEL TRIANGLE PLANTER BOX SKIRTING.
4) 3/16" STEEL PLANTER BOX ANCHORING BRACKETS.
5) BENCH & BAR CANTILEVER BRACKETS AND 2" STEEL PIPE SUPPORTS.
6) DRAINAGE GRATING: MCNICHOLS # 660130332 BAR GRATING; GLV. STEEL, 1.875 SPACING, 2.0% OPEN.
7) 1 1/2" X 1 1/2" ANGLE IRON LEDGERS @ PAVER PERIMETERS.
8) GVL STEEL CHECKER PLATE DECKING OVER STORM DRAIN.
 - 06 46 03 ARCHITECTURAL WOODWORK
TABLES, BARS & BENCHES: 2.5" X 5.5" STK (SMALL KNOT CEDAR), TYP.
 - 06 05 23 WOOD, PLASTIC, AND COMP. FASTENINGS
SIMPSON SDS25200 HVDUTY CONNECT. SCREW
 - 07 14 16 FLUID APPLIED WATERPROOFING
INNER PLANTER BOX WALL WATERPROOF COATING.
 - 07 21 00 THERMAL INSULATION
1/2" RIDGID INSULATION BELOW GRADE @ ALL INTERIOR PLANTER BOX WALLS.
 - 07 76 00 DECK PEDISTALS
FIXED &/OR ADJUSTABLE SCREW JACK PEDISTALS: BISON PRODUCTS/LEVEL IT LC 2"-4 3/4" ADJ. SCREW JACK PEDISTAL.
 - 07 76 00 PEDESTAL-MOUNTED PAVERS/PALLETS
OPTIONS:
24" X 24" CONC. PAVERS
 - 09 93 13 EXTERIOR STAINING AND FINISHING
NON-TOXIC WOOD PRESERVATIVE/STAIN
COLOR: CEDAR
 - 10 14 00 SIGNAGE: BY OTHERS
BUS STOP; PUBLIC SPACE; NO SMOKING; PARKLET PLAQUE
(E) BUS STOP & SCHEDULE INFO POSTED AT WEST LIGHT POLE
 - 12 93 13 BICYCLE RACKS: BY OTHERS
WELLE SERIES FLAT TOP; SQUARE TUBE; SURFACE FLANGE; #WSWF02-SQ-SF
 - 12 93 23 TRASH CANS: BY OTHERS
DOUBLE "BIG BELLY"
 - 32 94 33 PLANTS
PLANT LIST T.B.D.
MAIN PLANTING BEDS: NATIVE COASTAL SPECIES. TREE PODS: TBD.
 - 32 94 33 PLANTING/LANDSCAPING ACCESSORIES
WOVEN FILTER FABRIC; PVC 1/2" X 1/2" MESH; 3/4"-1" GRAVEL; PLANTING SOILS;
 - 34 71 19 FLEXIBLE VEHICLE DELINEATORS BY OTHERS
STREET CENTER LINE & @ SE PLANTER CORNER: FLEXSTAKE TRAFFIC DELINEATOR - 750 SERIES SURFACE MOUNT TUBULAR POST (OR EQUAL)

PARKLET PLAN NOTES

- 1. (N) DOUBLE BIG BELLY TRASH & RECYCLING CANS
- 2. (N) TREE(S)
- 3. 18" HIGH STOOL
- 4. 24" HIGH BAR
- 5. 30" HIGH WHEELCHAIR BAR
- 6. 36" HIGH PLANTER, TYP.
- 7. 30" HIGH (LOW) PLANTER
- 8. ARM REST
- 9. BENCH
- 10. BENCH & PLANTER
- 11. BIKE RACKS
- 12. COMPANION SEATING
- 13. FLEX DELINEATOR POSTS
- 14. SLOPED BENCH BACK
- 15. SURFACE MNT. DELINEATOR BOLLARD
- 16. TRANSIT PLATFORM
- 17. WHLCHR. RESTING PLACE
- 18. WHLCHR. TURN AROUND
- 19. N/A
- 20. 24" X 24" PAVER GRID
- 21. REMOVABLE 24" X 24" CONC. PAVER OVER PEDISTAL/ STEEL LEDGER OVER GUTTER, TYP.

Sponsor: Abraham & Bonnee Elterman
1205 Solano Ave., Albany, CA 94701
bonnee.elterman@gmail.com

DRAWN BY: STEPHEN HEINEN
SINGING HAMMERS, LLC
BOX 7 THERMOPOLIS WY. 82443
307.921.0860
stephenheinen@gmail.com

ISSUE

8/30/16 Concept
9/16/16 Scheme Selection
9/29/16 Commissioner Present.
1/18/17 "65% Review"
1/27/17 Traffic & Safety.
3/18/17 City Council

"AS YOU WISH" PARKLET
1205 SOLANO AVE. ALBANY, CA 94706

PLAN

A 1.1

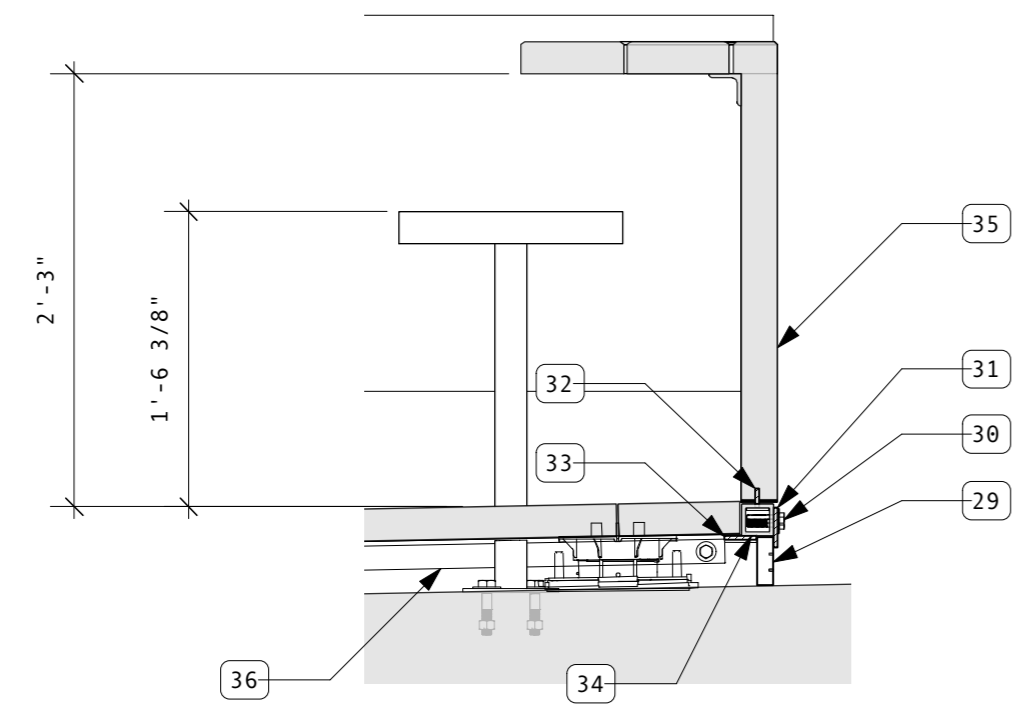

9 GUTTER GRATE & BEAM
Scale: 1" = 1'-0"

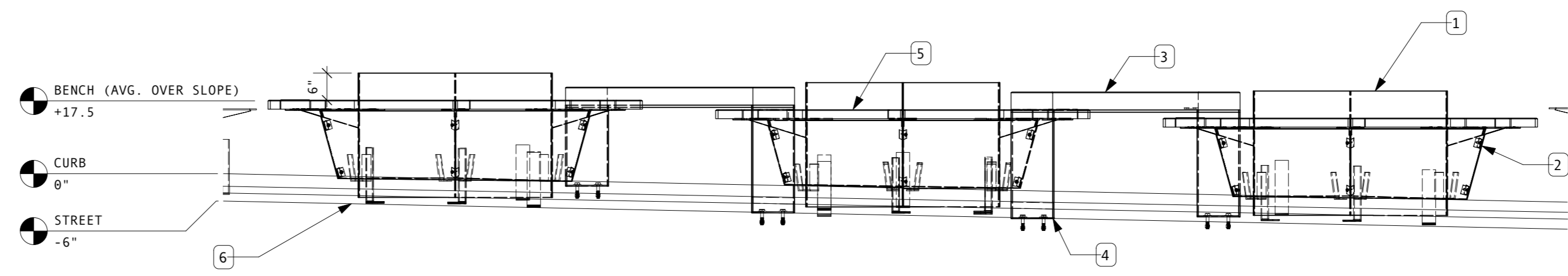

4 TRIANGLE PLANTERS & COFFEE BARS SOUTH ELEVATION
Scale: 1/2" = 1'-0"

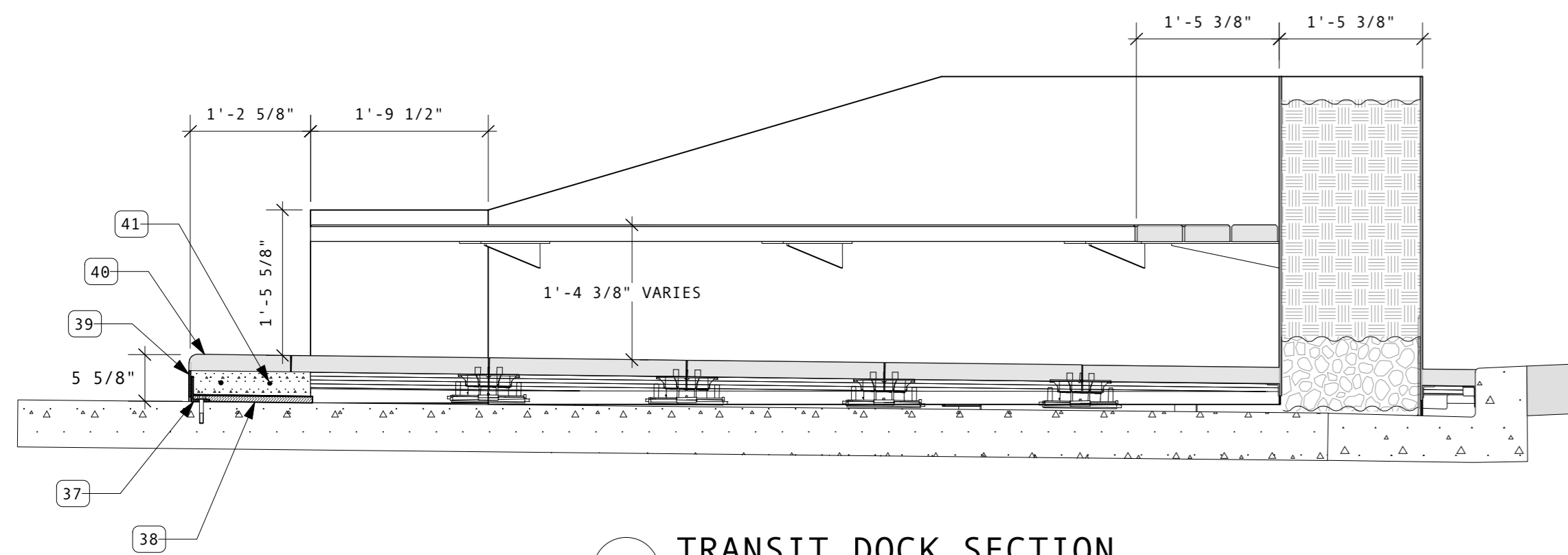

10 TRANSIT DOCK SECTION
Scale: 3/4" = 1'-0"

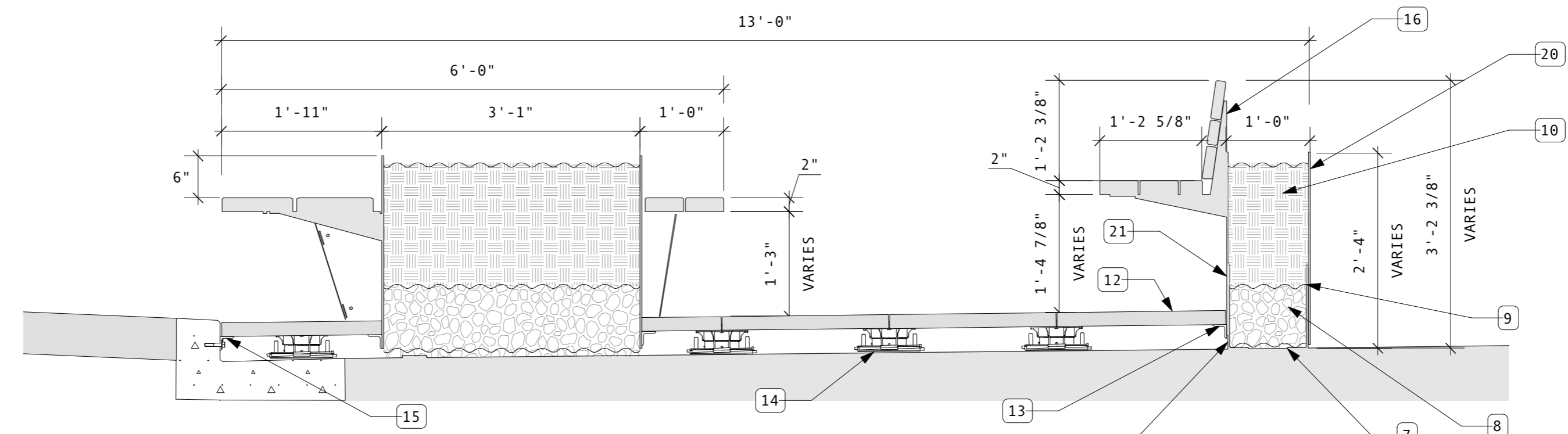

1 PARKLET SECTION DETAIL
Scale: 3/4" = 1'-0"

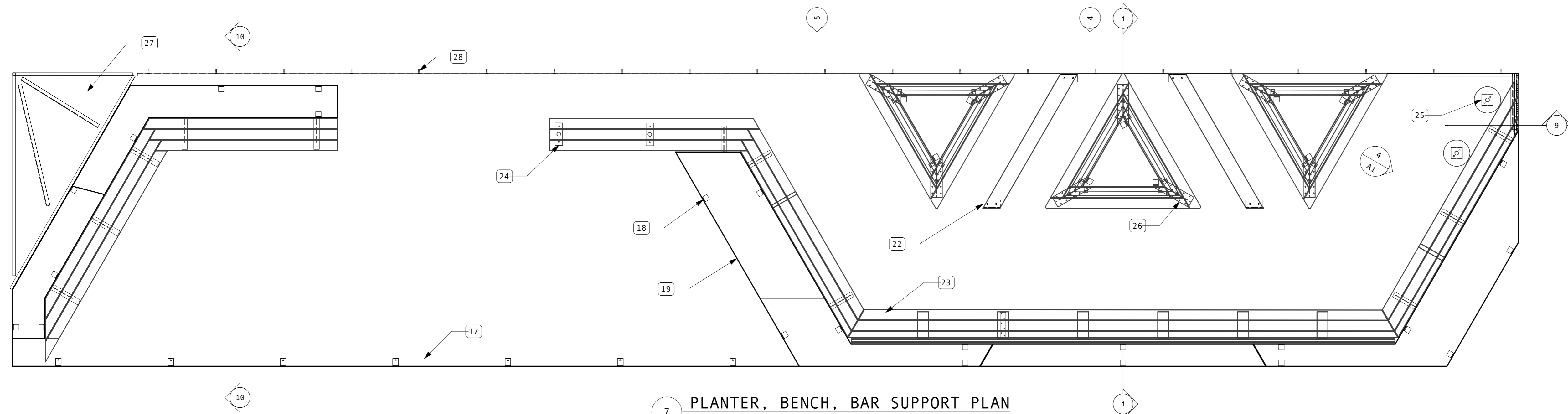

7 PLANTER, BENCH, BAR SUPPORT PLAN
Scale: 3/8" = 1'-0"

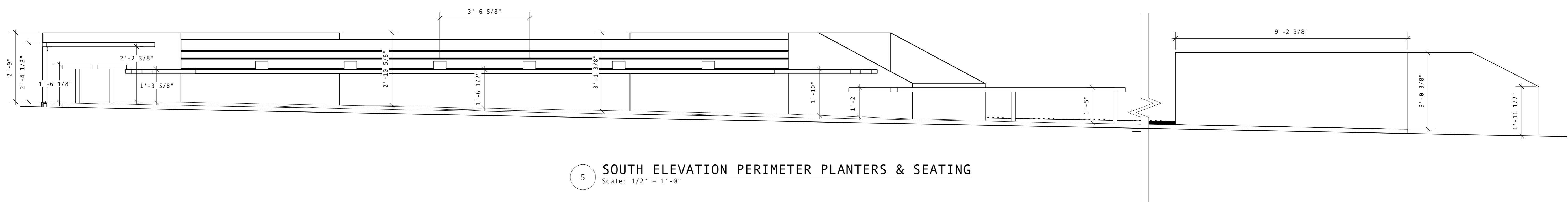

5 SOUTH ELEVATION PERIMETER PLANTERS & SEATING
Scale: 1/2" = 1'-0"

NOTES

- STEEL PLANTER PANELS; SQUARE & PLUMB; MITERED JOINTS; EASED CORNERS.
- REMOVEABLE 1/8" STEEL SKIRT; FIELD SET LEVELING LEGS; BOLT ATTACHMENT TO BENCH SUPPORT BRACKETS.
- 3.5" CEDAR PLANK COFFEE BAR; 5/16" CHAMFER TOP EDGE, TYP.; UNDERSIDE HIDDEN SDS SCREW ATTACHMENT TO STEEL SUPPORTS
- COFFEE BAR STEEL SUPPORTS; EXPANSION OR EPOXY BOLT ATTACHMENT TO STREET.
- 2" PLANK BENCH SEATING; 5/16" CHAMFER SURFACE EDGE, TYP.
- 2% SLOPE, TYP.
- 1/2" X 1/2" PVC MESH
- 3/4" - 1" GRAVEL
- WOVEN FILTER FABRIC
- PLANTING SOIL
- 1/4" STEEL PLANTER LEG; FIELD INTALL TO GRADE; NO ANCHOR, TYP.
- PAVER
- 1 1/2" ANLGE LEDGER; WELDED FIELD INSTALL. TYP.
- ADJUSTABLE SCREW JACK, TYP.
- 1.5" ANGLE LEDGER @ CURB; 1/2" X 3" REDHEAD ANCHORS 36" O.C., TYP.
- 1/4" STEEL BENCH BRACKET
- CURB FACING BRACKET & ANCHOR
- 1/4" GLV. STEEL PLANTER SUPPORT (FOOT); FIELD INSTALL (NO ANCHOR)
- 1/4" STEEL RECTANGULAR PLANTER WALL; MITERED JOINTS; BEVELED & EASED EDGES, TYP.
- STREET FACING PLANTER PANEL MAINTAIN 1/2" REVEAL @ BOTTOM EDGE ABOVE STREET SURFACE, TYP.
- INTERIOR RECTANGULAR PLANTER WALL. 1.5" AVERAGE CLEARANCE ABOVE STREET SURFACE, TYP.
- COFFEE BAR FOOT ATTACHMENT; 1/2" X 4" ANCHOR BOLT (EXPANSION OR EPOXY) TYP.
- 1/4" STEEL WELDED CANTILEVER BENCH BRACKET, TYP.
- PIPE BENCH SUPPORT & BRACKET; 1/2" X 4" ANCHOR BOLTS (EXPANSION OR EPOXY) TYP.
- PIPE STOOL SUPPORT & BRACKET; 1/2" X 4" ANCHORS (EXPANSION OR EPOXY) TYP.
- 1/4" STEEL BENCH SUPPORT, TYP.
- 1/8" GLV. STEEL CHECKERPLATE STORM DRAIN REMOVEABLE COVER.
- 1/2" X 2 1/2" REDHEAD ANCHOR BOLT, 36" O.C., TYP.
- BAR GRATING
- 1/2" X 2" MB
- REMOVABLE FACE PLATE
- 1/4" X 1" SPLINE @ VERTICAL WOOD PLANK BASE
- 1/4" X 2" STL. FLAT BAR LEDGER
- 2" X 2" TUBE STEEL BRIDGE
- 2.5" X 5.5" TKS CEDER PLANK
- 2" X 2" ANGLE IRON
- MOUNTING BRACKET & ANCHOR BOLT
- HALF PIPE DRAIN CHANNEL
- 1/4" STEEL FACIA
- BULLNOSE PAVER ON MORTOR BASE
- #4 REBAR

Sponsor: Abraham & Bomnee Elterman
1205 Solano Ave., Albany, CA 94701
abomnee.elterman@gmail.com

DRAWN BY: STEPHEN HEINEN
SINGING HAMMERS LLC
BOX 7 THERMOPOLIS WY. 82443
307.921.0880 stephenheinen@gmail.com

ISSUE

8/18/16 Concept
9/19/16 Scheme Selection
9/19/16 Commissioner Present.
1/28/17 "15" Review
1/27/17 Traffic & Safety.
3/19/17 City Council

"AS YOU WISH" PARKLET
1205 SOLANO AVE. ALBANY, CA 94706

ELV
SEC
DETAILS

A 2.1